



SCORPION

Assembly Manual

AVIATION DESIGN

ZI le chenet, 91490 Milly La Foret, FRANCE

Tel : 33 1 64 98 93 93

Fax : 33 1 64 98 93 88

*E-mail : aviation.design@wanadoo.fr
www.adjets.com*

Version 01/01/2008

INTRODUCTION

SCORPION is our new jet trainer. It is fully composite, delivered assembled and painted.

It is designed for jet beginner with following objective :

- Very easy to fly.
- Short take off and landing due to big airfoil thickness (13%), large flaps and low wing loading
- Very fast assembly
- Easy access to engine (big engine hatch)
- Easy access to fuel tank , ECU and radio with a large fuselage hatch
- Easy radio installation with big fuselage hatch and servo cover supplied

The **SCORPION** is fully molded in composite material.

The model comes to you finished, fully molded in composite material and painted in mold. All bulkeads are glued. All control surfaces are hinged. No gluing are required. This model has plug in wings, stabs and fin booms for an easier transport.

All necessary hardware are included in the parcel

Assembly require only few hours to fit engine and radio.

SCORPION ARF model includes :

- High quality epoxy-glass fuselage painted.
- All plywood and wood parts premounted.
- Fully molded wings with winglets, stabs and fins painted
- High tensile aluminum wing joining tube.
- Access hatch and canopy requiring no additional framework.
- All hardware (screws, servo cover, ...)
- Instructions in English with pics.

Parts required to complete the kit :

- 3.2 liters kevlar fuel cell
- or 3.2 liters kevlar tank + UBT
- Deluxe retractable landing gear with special CNC oleo legs and wheels set on bearing + brakes
- Or Deluxe gear + electrovalve fro gear and brakes
- Air brake
- Steel exhaust pipe



DISCLAIMER

AVIATION DESIGN assumes no liability for the operation and use of these products.

The owner and operator of these products should have the necessary experience and exercise common sense. Said owner and operator must have a valid Model Airplane licence and insurance as required.

Assembly Instructions

Installation of the radio equipment

Components need:

Elevator: 1 servo 5 kg torque

Rudder: 2 mini servos 3 kg torque (Hitec HS-225)

Ailerons: 2 mini servos 3 kg to 4 kg torque (Hitec HS-225MG)

Flaps: 2 mini servos 4 kg torque (Hitec HS-225MG)

Steering nose wheels: 1 servo 3 kg torque

Receiver and switch

Canopy hatch:

Make a 6 mm hole in front of the fuselage hatch for the wood pin.



Glue the wood pin with CA in the hatch

Drill the corresponding hole in the front fuselage

Cut a slot and make a 3 mm hole in the back of the canopy for the hatch latch

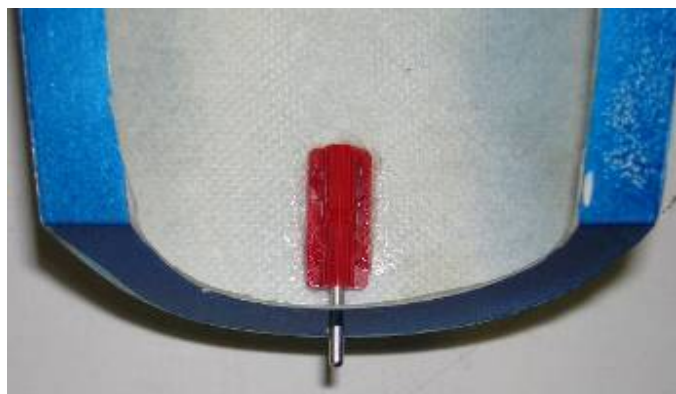

Glue the hatch latch with CA. Take care to not glue the metallic part
Fit the hatch on the fuselage and draw the corresponding hole
Drill the 3 mm hole in the fuselage



Fuselage hatch:

Make a 6 mm hole in front of the fuselage hatch for the 2 wood pins.
Glue the wood pin with CA in the hatch

Drill the corresponding hole in the front fuselage

Cut a slot and make a 3 mm hole in the back of the hatch for the hatch latch
Glue the hatch latch with CA. Take care to not glue the metallic part
Fit the hatch on the fuselage and draw the corresponding hole
Drill the 3 mm hole in the fuselage



Fitting the dorsal air brake

Fit robart hinges in the 2 aluminium tube
Glue the 2 aluminium tube with CA on the airbrake. Take care that the hinge point is at the air brake limit (see pic)



Glue the 2 Robart hinges in the tube with epoxy.
Bend the hinges at 90° to be sure they are parallel



Screw the M2 link to the threaded rod
Glue the threaded rod in the air cylinder rod

Connect the M2 link to the plywood horn
Glue the plywood horn in the center of the air brake as the pics.
Axis of the link must be at 130 mm from the end (see pics)

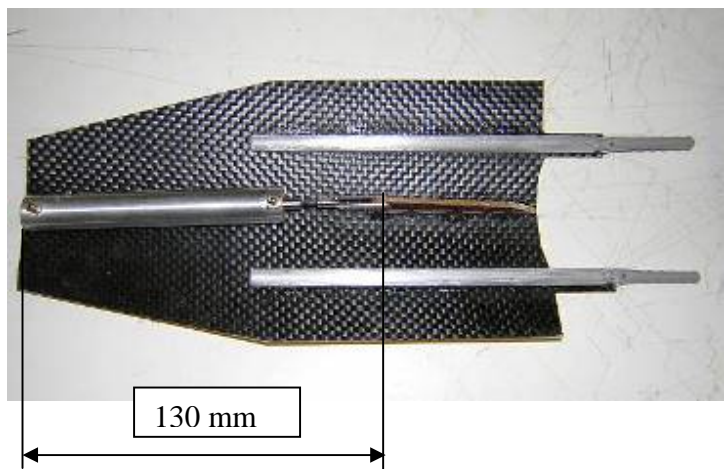

Fit the 3 mm threaded rod in the air cylinder end
 Fit 2 M3 screws to lock the air cylinder in the middle of
 the threaded rod. Secure the screws

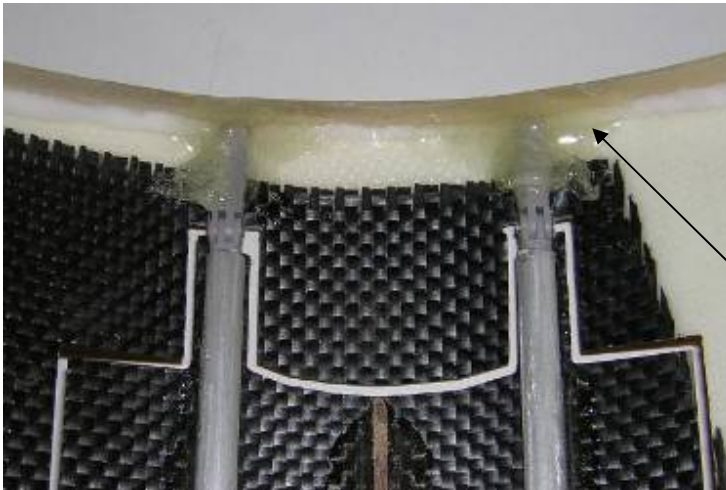

Cut the end of the hinges to fit in the
 fuselage hatch

Send the 2 air brake pads with an angle so that
 the air brake can open and closed without
 problem (see pics)

Glue the 2 hinges on the fuselage with CA. Take
 care to not glue the axis (put oil on it).

Take care that the airbrake is perfectly centered
 in the hatch

Secure the hinges with epoxy

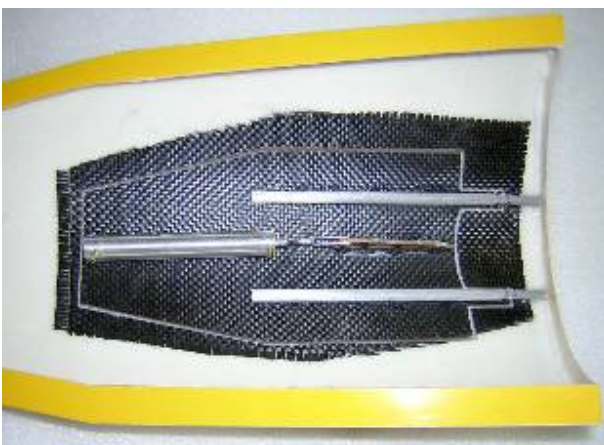
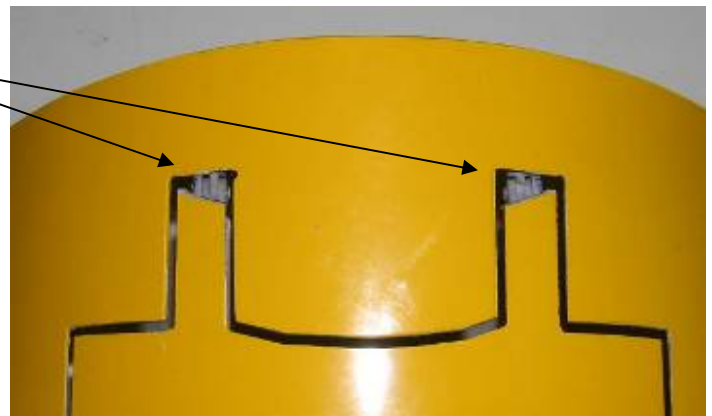

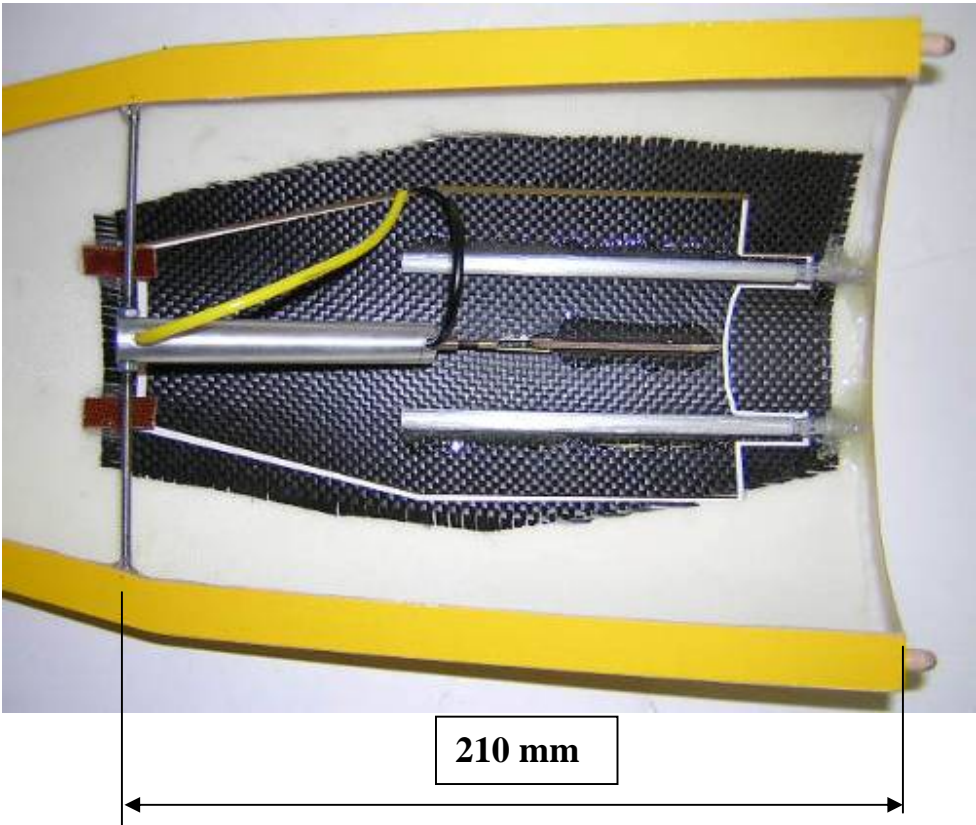

Adjust the position of the that the air cylinder is fully closed when air cylinder is closed and open with cylinder open. Distance is approximatly as the drawing

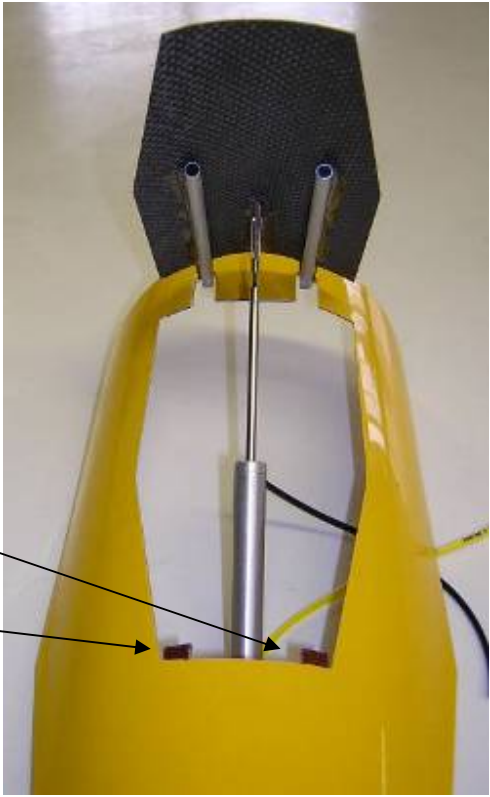
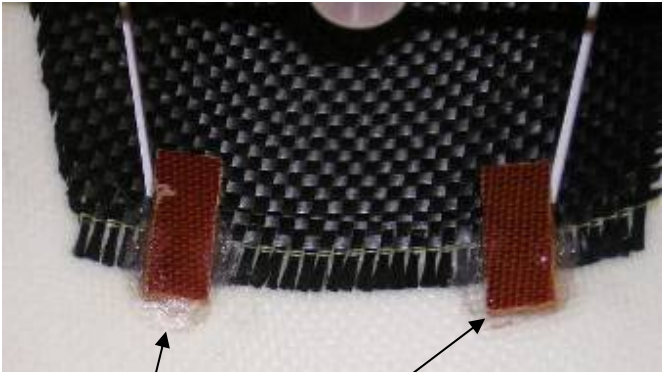

Glue 2 pieces of fiber or plywood at the end of the air air brake hatch to have a air brake stop

Joining front fuselage to rear fuselage

Glue the plywood reinforcement on front and rear fuselage

Drill 4 x 3 mm hole in the front fuselage on the engraved location

Drill 4 x 4 mm hole in the rear fuselage on the engraved location (corresponding to front holes)

Insert 4 x 3 mm blind nut in the rear section

Screw the front fuselage to the rear fuselage with four 3 mm x 20 mm allen screws

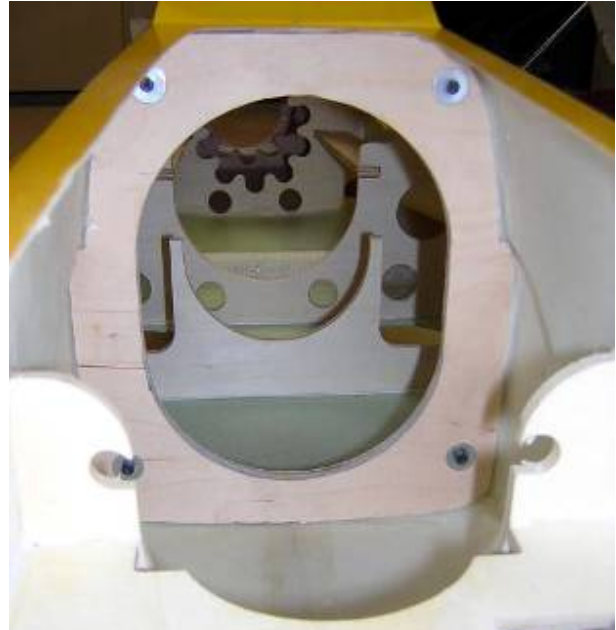

Stabs

Servos installation

Important : the servo MUST be a high quality servo, 8 kg torque, with metallic gears.

Screw the servo on the plywood mount

Glue the 2 plywood mounts as the pics.

Now, this parts must be glued with epoxy and glass fiber in the fuselage against the rear engine frame.

The servo lead must be fixed to the fuselage and protected from engine.

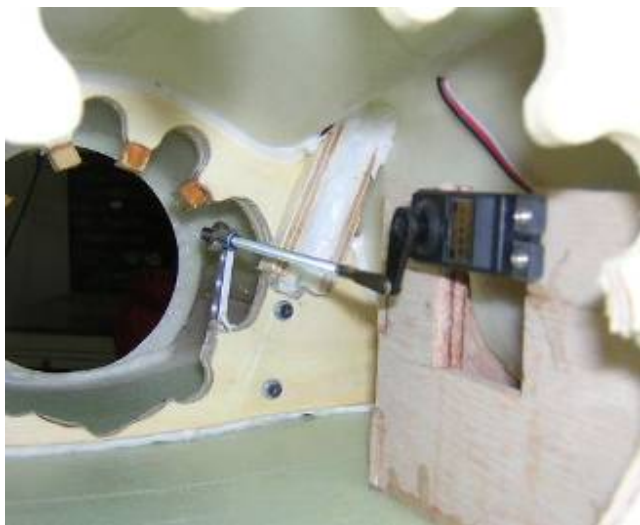
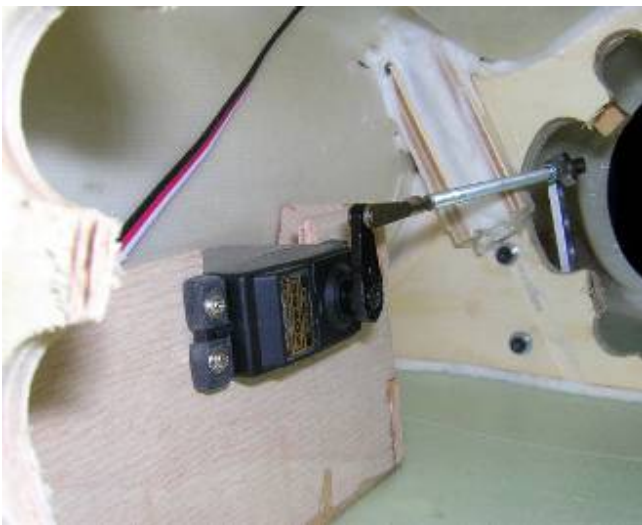
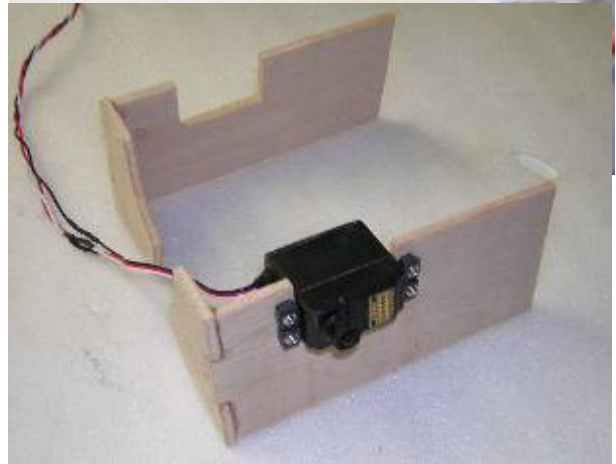

Stabs installation

Important : the 2 stabs **MUST** be balanced to have no flutter.

Normally, the stabs are pre balanced in factory.
Anyway you have to check if the stab are already balanced

When the stabs are fitted in the tubing, they must be free in rotation : not hard point, no unbalance.

If it is not correct, you will have to drill a hole in the stab root and glue some lest in the leading edge to balance them.

You will need approximately 35 grams of lest per stabs.

When the stab is fitted in the tubing, it must be free in rotation : not hard point, no unbalance.

Now you have to glue with epoxy the 2 aluminium pin (d; 8 mm x 20 mm long) in the stab tube to reinforce them when you will have to drill and tapered

Send the aluminium pin and insinde the aluminium tube for best glue adhesion. Insert some epoxy in

Slide the stab in the tube.

Check the clearance of the stab and the fuselage. touch the fuselage when it rotate. If necessary sli stab don't touch the fuselage

Slide the aluminium control arm on the tube

Put the stab horizontal.

Put the control arm vertical.

Drill a 2.5 mm hole through the arm and through the aluminium tube.

Tapping them with M3 screw-tap.

Connect the servo to the arm with the large M4 ball link, M4 threaded rod and M3 metallic link
Glue them with threadlock.

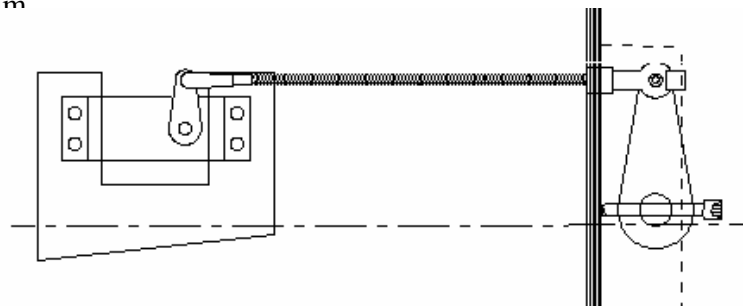
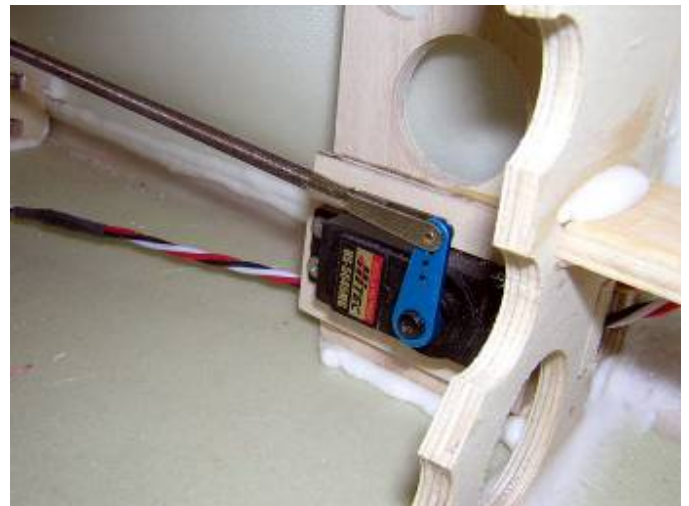

Gear :

Please, use only the oleo legs supply by Aviation Design.

If you use standard oleo, you will have to modify the gear position and gear door position

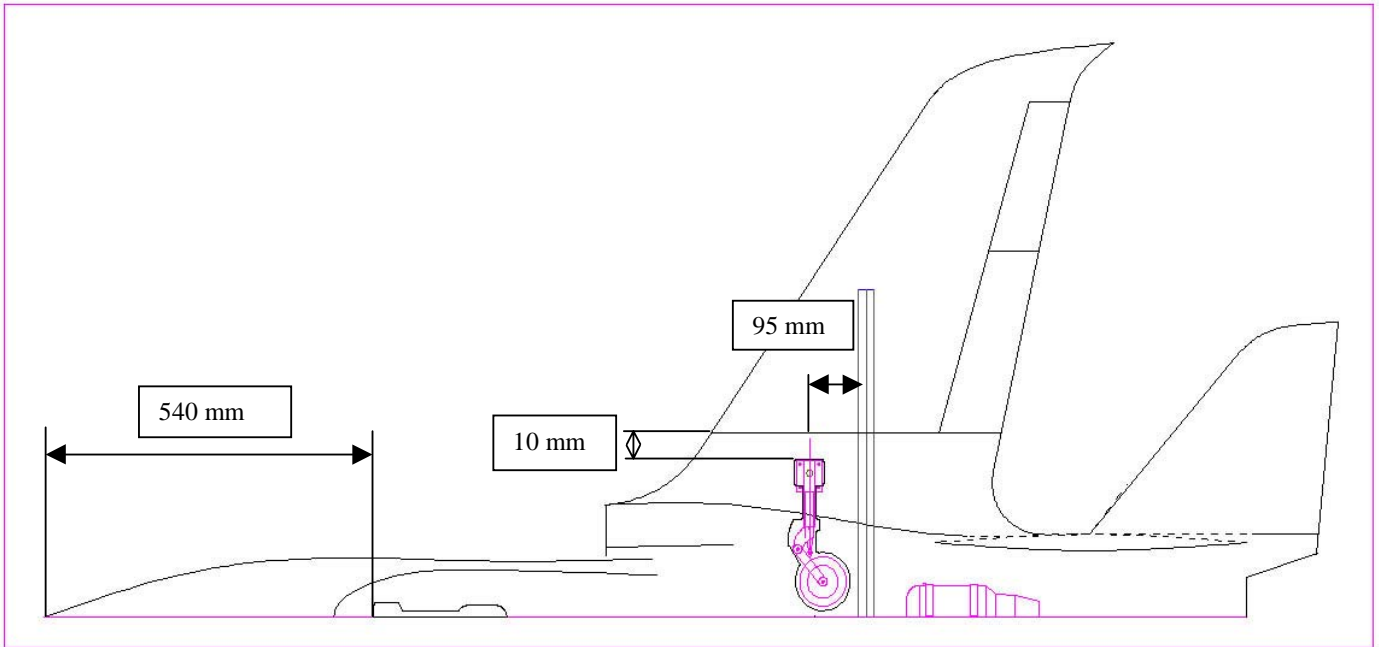

Draw the fuselage axis under the fuselage with a ruler

Draw the front gear door location and main gear door location according to the drawing and template



Cut all gear doors using a fine diamond disc and dremel tool



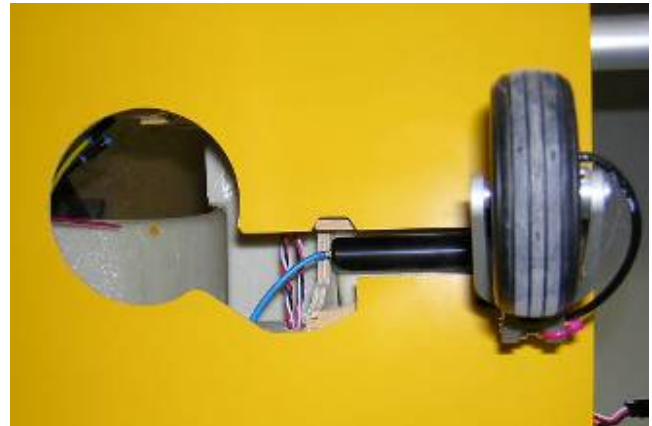

Fit the main gear on the plywood mount a drill four 2 mm hole
Screw each gear with four 3x20 mm parker screws

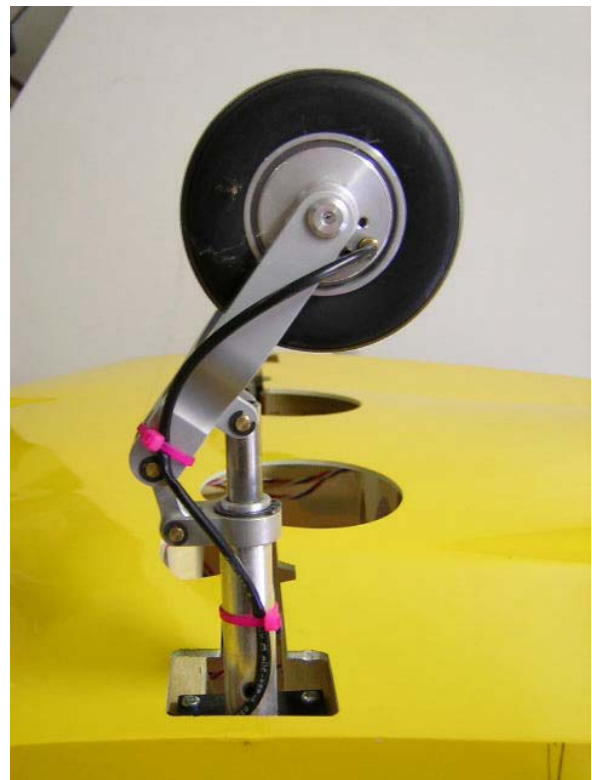

Connect all gear tubing as described in the gear manual
Fit the brake tubings and attach them with T rap

Fit the front gear on the plywood mount
Drill 4 x 2 mm hole
Screw the front gear with four 3x20 mm parker screws



Screw the steering servo on the plywood frame

Make a hole in the plywood frame for the steering steel wire.

Connect servo to steering arm with 2 mm link + steel wire .

Check that the nose gear retract and extend without problem with the steering wire.

If necessary, add 2 soft springs or rubber bands to extend the wire when the front gear retract

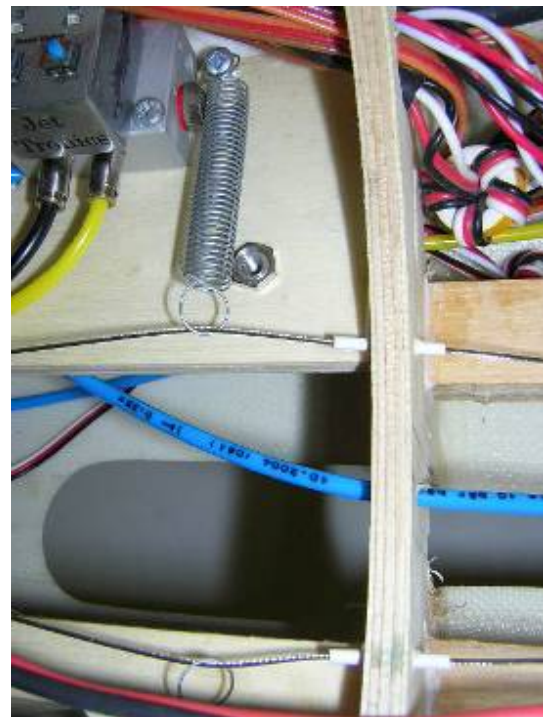

Aileron and flaps servos :

If necessary increase the hole for the servo location in the wings with a permagrit rotating tool for the aileron and flaps

Screw the servo in the servo cover (we recommand to glue it with silicon glue for more security)

Put in position the servo cover on the wings

Drill 4 x 1 mm hole in the wings for the screws



Cut a slot in the control surface for the fiber control horn

Glue with fast epoxy the control horn

Connect two 2 mm link with M2 threaded rod

Screw the servo cover with the 4 parker screws

Connect the servo with the control horn

Apply thread lock.



Aileron control horn

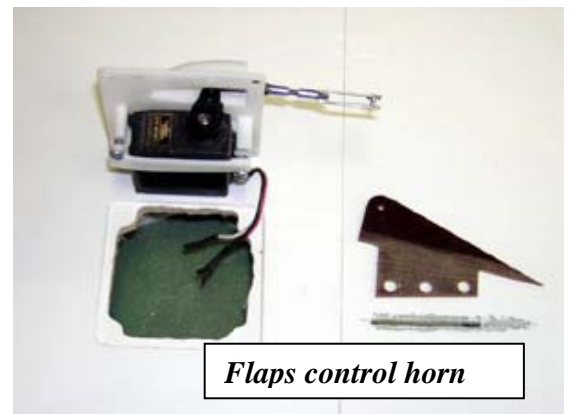

Flaps control horn

Make a 15 mm hole in the wing root for the servo electric wire
Don't make the hole too big so that the connector can't fall in the wing

Sold electric wire for the flaps and aileron



Make a 5 mm corresponding hole in the fuselage for the electric wire
Don't make the hole too big so that the connector can't fall in the fuselage



Wing pins

Sand half of the wing pins to glue them in the wings
Glue them in the wing with epoxy

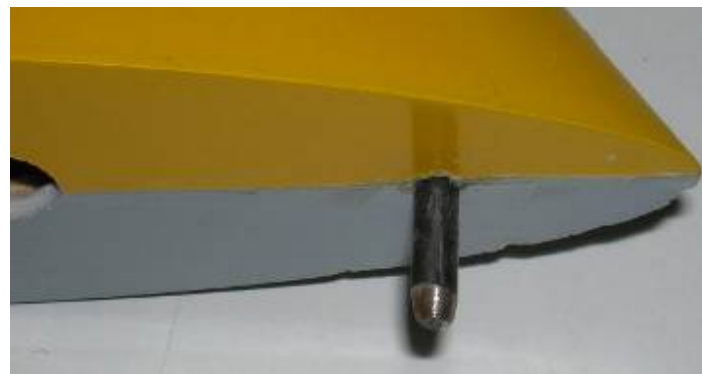
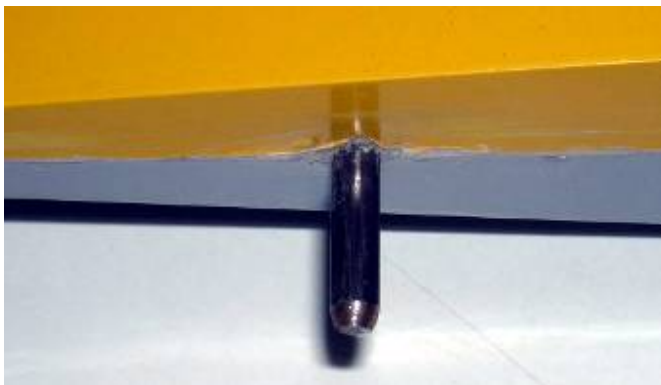

Secure the wings :

Fit the wing joiner tube through the fuselage.

Take care to put it at the center (same length left and right (about 220 mm).

Install the left and right wings.

There is a plywood reinforcement in the bottom of the wing skin to drill a hole for the screw.

Make a 2.5 mm hole at 50 mm from the wing root through the wing (lower skin) and through the aluminium tube to secure the wings

Thread the wing tube and wing at M3 mm and secure wings with a M3x25 screw

You can also secure the tube in the fuselage.

Make a 2.5 mm hole in the center of the fuselage from the engine hatch. Drill the hole through the fiber tube and aluminium tube to secure the tube.

Screw a 3 x 16 mm Parker screw through, so the tube will not move during assembling and disassembling.

If you don't secure the tube in the fuselage, you can just draw on the aluminium tube the wing limit and an up / down mark to find easily the hole for the wing screw when you assemble the model.



Rudder servos :

Process as the wing servo :

Increase the hole for the servo location in the booms with a permagrit rotating tool for the rudder

Screw the servo in the servo cover (we recommend to glue it with silicon glue for more security)

Put in place the servo cover on the fin

Drill 4 x 1 mm hole in the wings for the screws

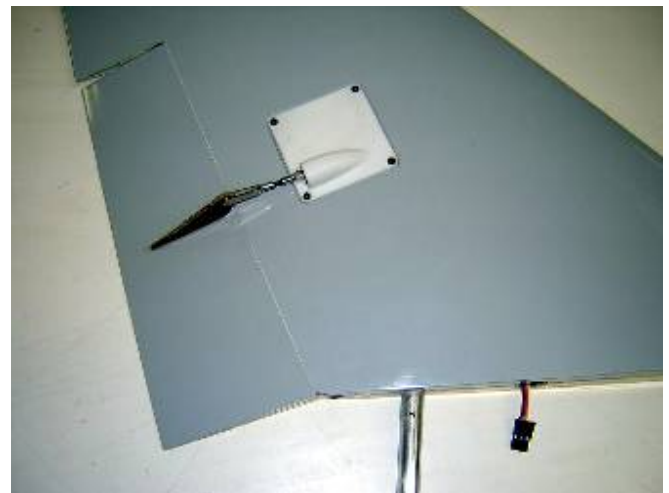
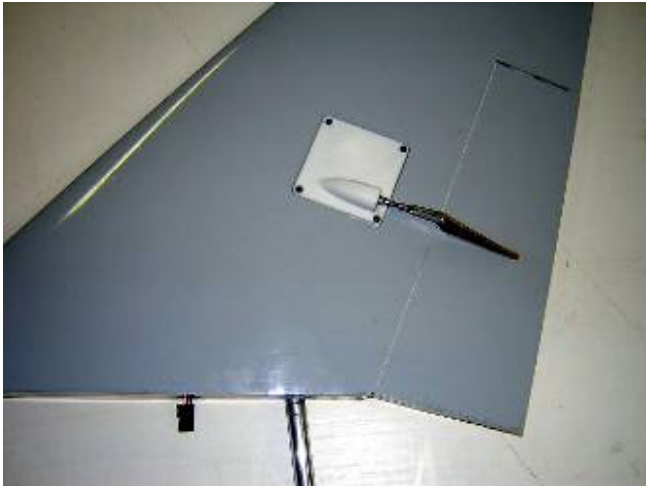

Cut a slot in the control surface for the fiber control horn

Glue with fast epoxy the control horn

Connect two 2 mm link with M2 threaded rod

Screw the servo cover with the 4 parker screws

Connect the servo with the control horn

Apply thread lock.



Make a 20 mm hole in the fin root for the servo electric wire.



Make a 5 mm corresponding hole in the fuselage for the electric wire.
Don't make the hole too big so that the connector can't fall in the fuselage.

Sold electric wire for the 2 rudder in Y

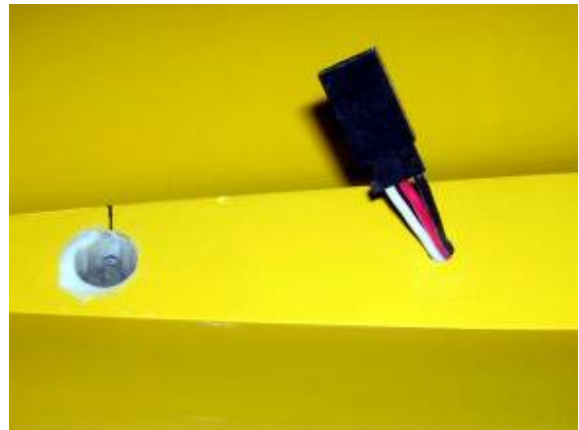

Secure the fins :

Fit the fins on the fuselage.

Make a 2.5 mm hole at 15 mm from the fin root through the fuselage and aluminium tube to secure the fins
Threaded the tube and fuselage at M3 mm and secure fin with a M3x15 screw

Fuel tank

Connect the fuel tank to the clunk as the photo. Check that there is no leak before to fit it in fuselage.

Drill a 3 mm hole in the bottom of the fuselage for the fuel vent

The fuel tank is connected to the small catch tank (200 cc) or UAT catch tank to be sure that there is no bubble in the fuel line.

The tubing from the main tank to the catch tank and to the catch tank to the fuel pump must be gasoline tubing (no silicone tubing). Also for the air vent tube.

The catch tank is glue with double face tape or with rubber band on the top of the main tank.

Hold the fuel tank with rubber bands or silicon glue

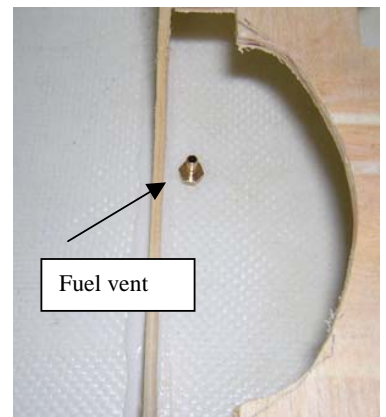

Filling the fuel tanks :

Connect your pump and fill the system in direction of the tank. It will first fill the catch tank and after the main tank. The main tank will be full when fuel come from the air vent tube.

When tanks are full, close the filling tubing. Do not close the air vent tube after. The system is ready for starting.

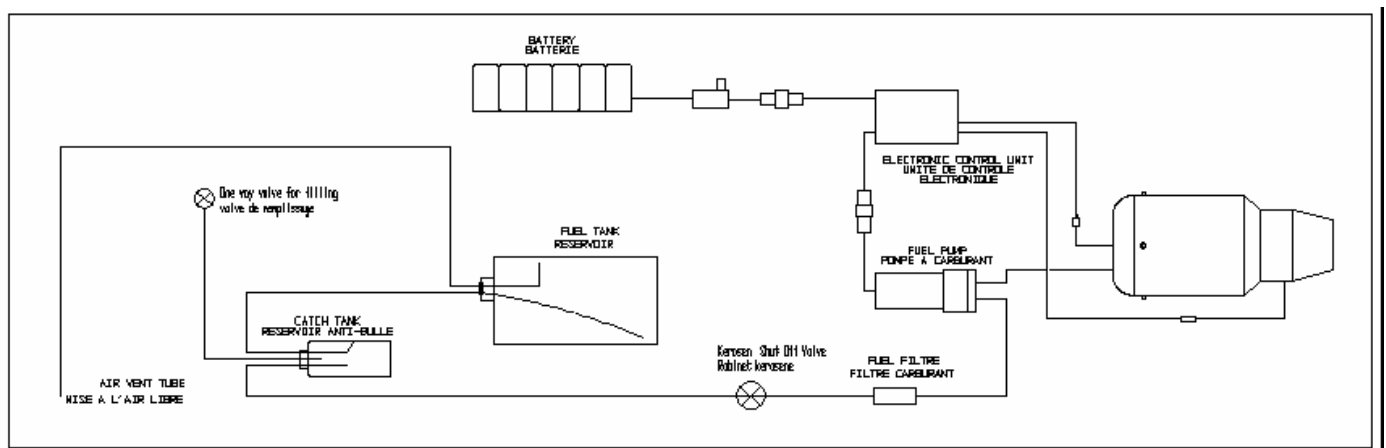

STEEL TAILPIPE EXHAUST

We recommend to secure the aluminum ring, the 2 steel pads and the tailpipe with 3 rivets or parker screw.

Fit in the fuselage the tailpipe from the fuselage hatch.

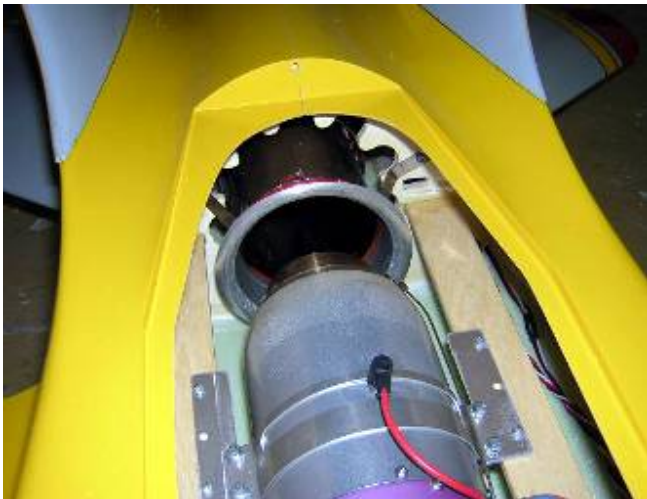

Tailpipe will be screw on the rear engine frame with 3 x 3 mm diameter parker screw at 120°

The end of the pipe will be hold by the fiber exhaust cone on the double welded steel sheet

Fiber exhaust cone :

You can also simply hold the tailcone with 2 parker screws that you can fit from inside the tailcone between the exhaust tube and the tailcone



Engine installation :

Adjust the position of the engine / beginning of the exhaust tube

The engine must be screw with 4 times 3x20 mm parker screw to the rear position.

Secure all electric wire and fuel tubing in front of the engine in the fuselage



ECU installation :

Fit the ECU in one side of the plane.
Fit the fuel pump and valves just rear to the ECU and hold them with T rap.

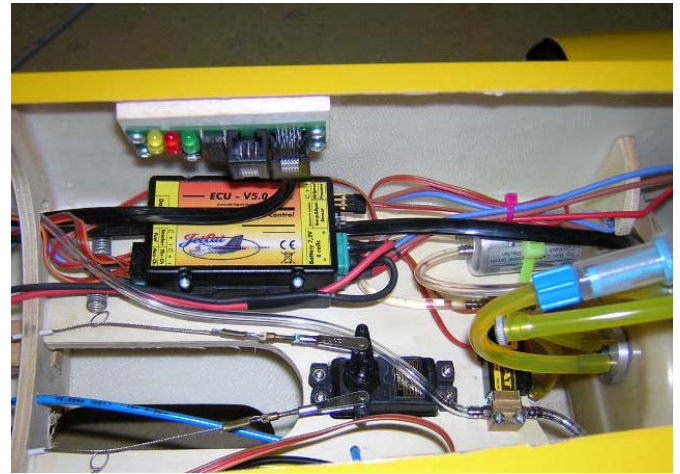

Gear valves, air tank, batterie, antenae

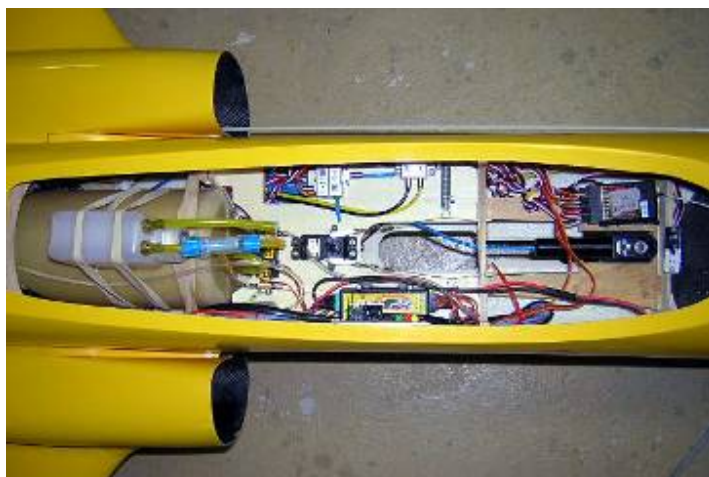

Clear Canopy

If you choose to fit the clear canopy, follow the next steps :

Cut the fiber canopy as the pics. Keep enough fiber border to glue the front pin and hatch

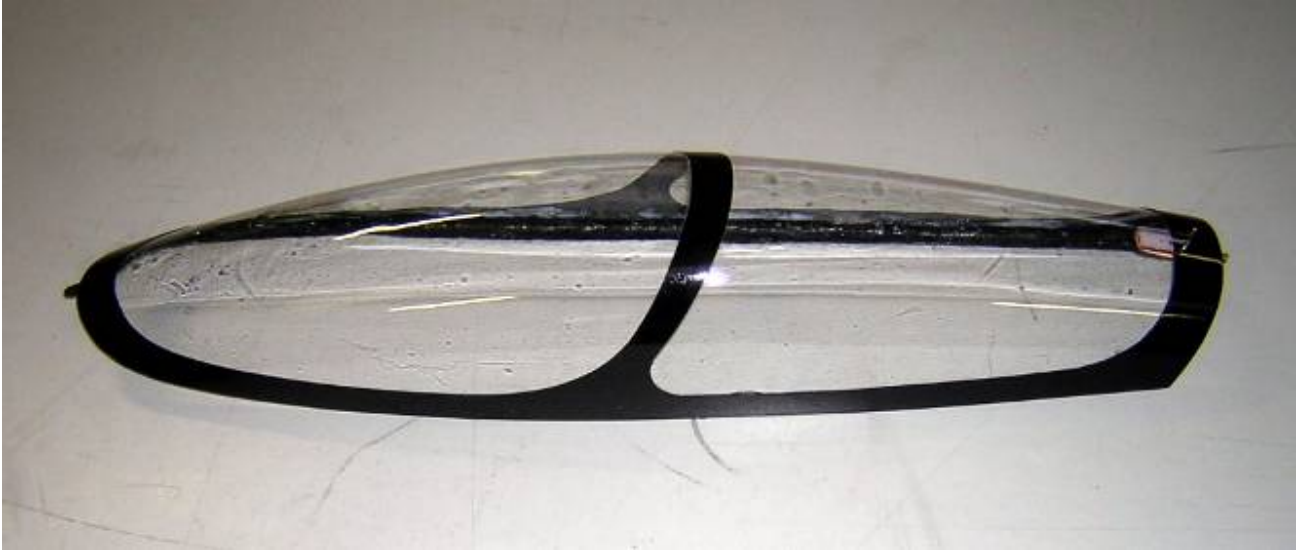

Glue the plastic vaccum parts together (see pics)

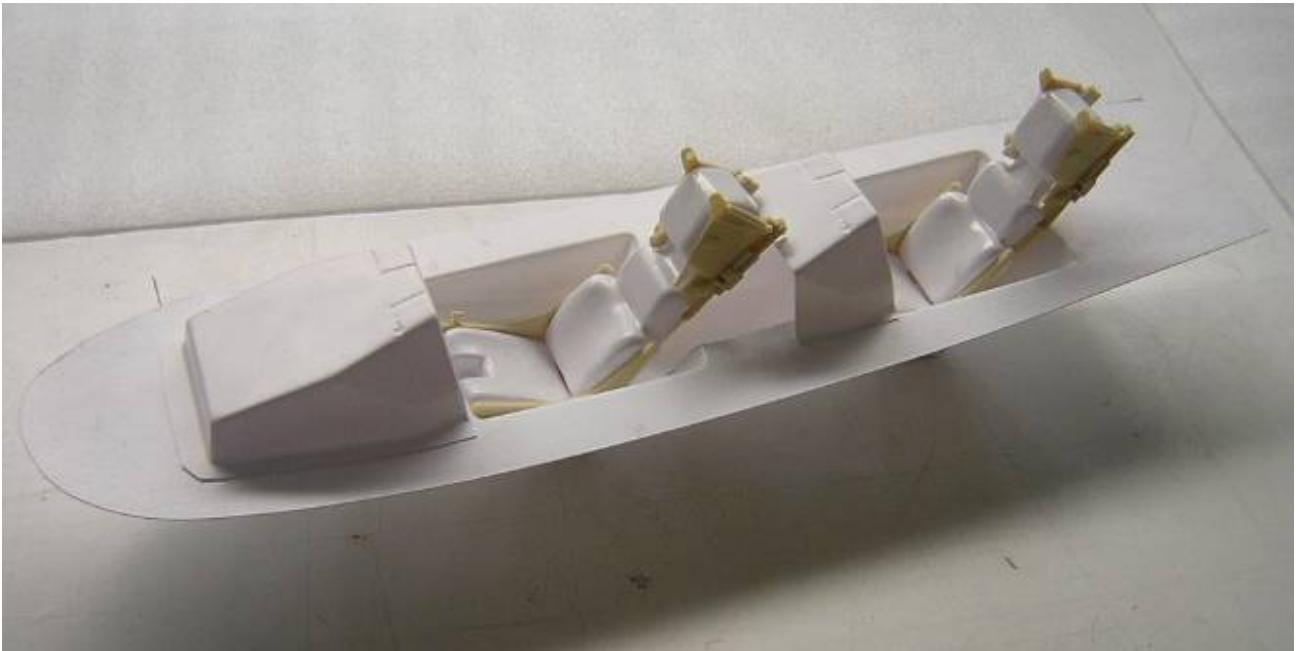

Paint all the internal parts in black and grey

Cockpit detail kit :

The first step is to assemble the ejector seat :

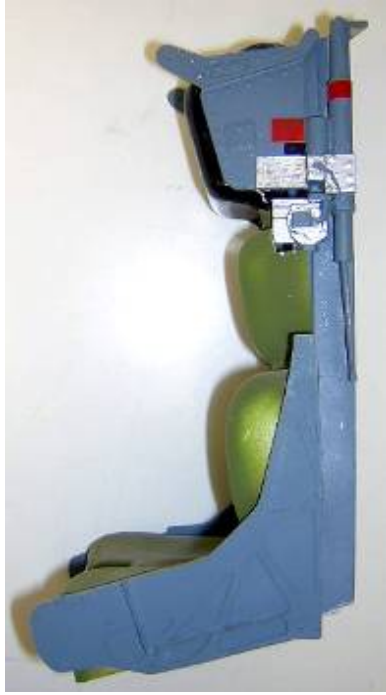

1- Paint : You can paint directly all plastic parts without sanding.
Use Enamel paint #144 and #98

2- Cut vacuum parts with small cisor

3- Glue : All parts can be glued together with cyano according to the plan.

Remove paint before to apply some CA on parts

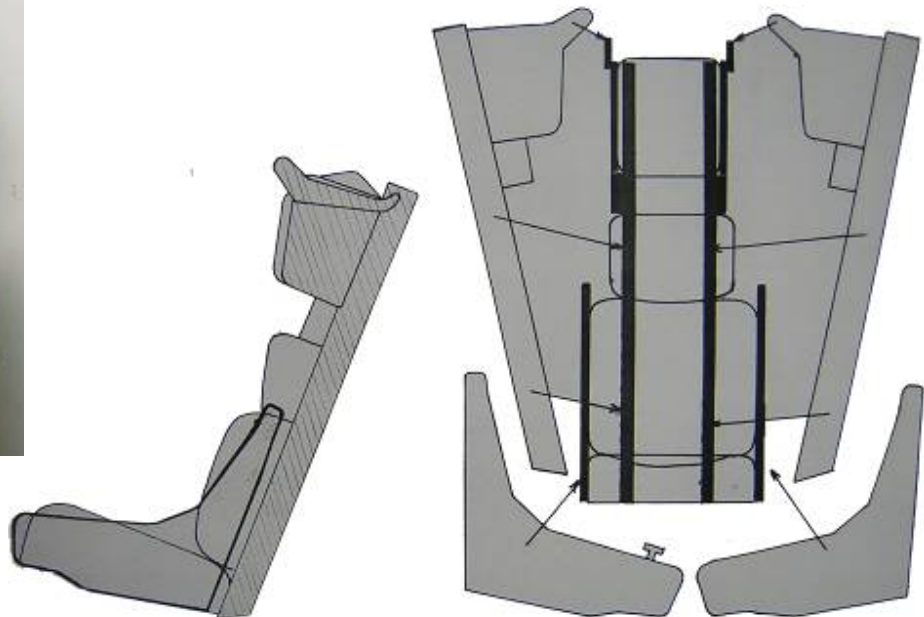

Paint the pilot : helmet, seat belts,

Glue with CA the plastic part at the rear of the ejector seat.



The third step is to fit all the part in the cockpit vacuum part

Fit the ejector seat in the ABS vacuum part.

Fit the pilot and instrument panel.

You should have to heat the pilot (with a air gun heater) to fit it in the cockpit with the good angle and to slide the instrument panel between its legs.

Glue the ejector seat in first.
After glue the pilot.



Radio installation :

Fit the radio in the nose section with batterie.

Adjust batterie position to have to correct CG position.

Don't put the received and aerial antennae too close the the ECU

Retract valve and brake valve can be fitted as the pics

Recommended surface throws

Ailerons

Up : 20mm Down : 20mm Exponential: 10

Rudder

15 mm left and 15 mm right Exponential: 10

Flaps

25 mm down with also mix 2 mm up elevator for pitch down moment

45 mm down with also mix 6 mm up elevator for pitch down moment

All measured in the widest part of the surface

Elevators

Up 40 mm Down 25 mm Trim : 5 mm up Exponential: 10

All measured at the trailing edge of the stab

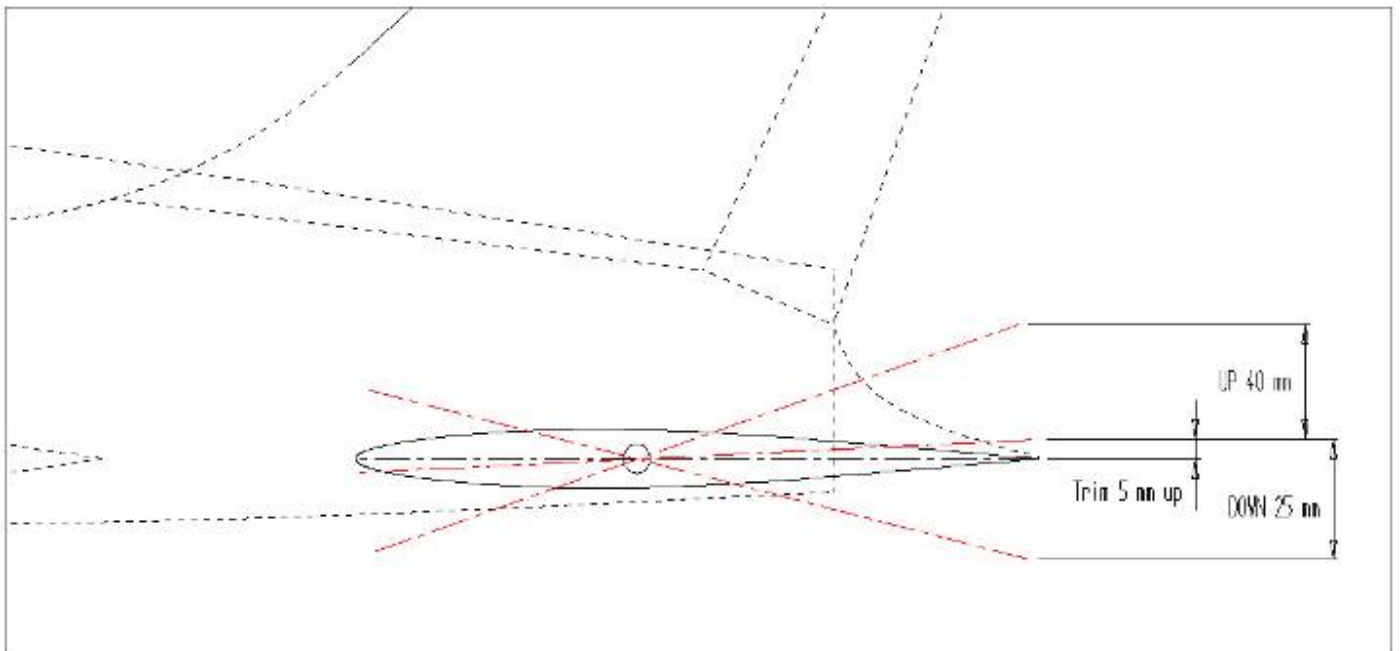

Center of gravity

You normally need 2 x 1700 Mah battery + ECU battery in the nose to have a correct Centre of Gravity.

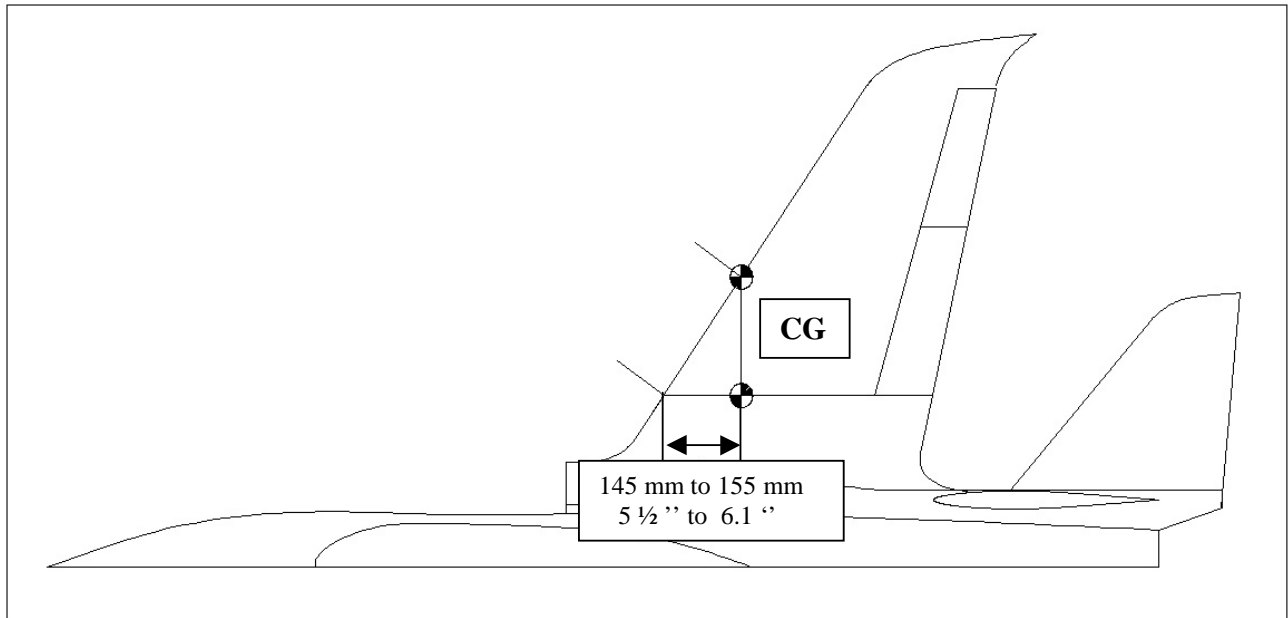

Note : balance the model with the gear down and the tanks empty.

The center of gravity (CG) must be located between 145 mm (forward position) to 155 mm (backward position, on the main gear leg axis) rear of the wing leading edge (wing root)

You must check it before the first flight, to do this with the aircraft in flight condition but without fuel lift the aircraft in this point, the aircraft must adopt a slightly nose down attitude. If it is horizontal or the tail drops move the batterie forward or add weight in the nose.

In other hand if the nose drops considerably add weight in the tail.

An easy way to adjust the CG on the Scorpion is to remove a little bit the wings from the fuselage and to slide a strong rope between the wings and under the fuselage against the main oleo legs (rear position). Slide again the wings against the fuselage and hold the plane by the rope. It should adopt a slightly nose down attitude.

Total weight

The total weight of the **SCORPION** is 10.0 kg tanks empty.

Important note : Pay very careful attention to structural integrity. This jet can reach speeds of over 350 KPH - 250 MPH. It is your responsibility to operate it safely.

Specifications may change without notice.

Gabarit de trappe de train
Gear door template
for behotec gear

