

**Read through this manual carefully before you begin building and follow it during construction.**

# **BOOMERANG ELAN ARF KIT.**

**Aerobatic Sport Jet for 12 to 20 lb. thrust turbines.  
Speed Range from 20 to 185 MPH.(32 to 296 KPH).**

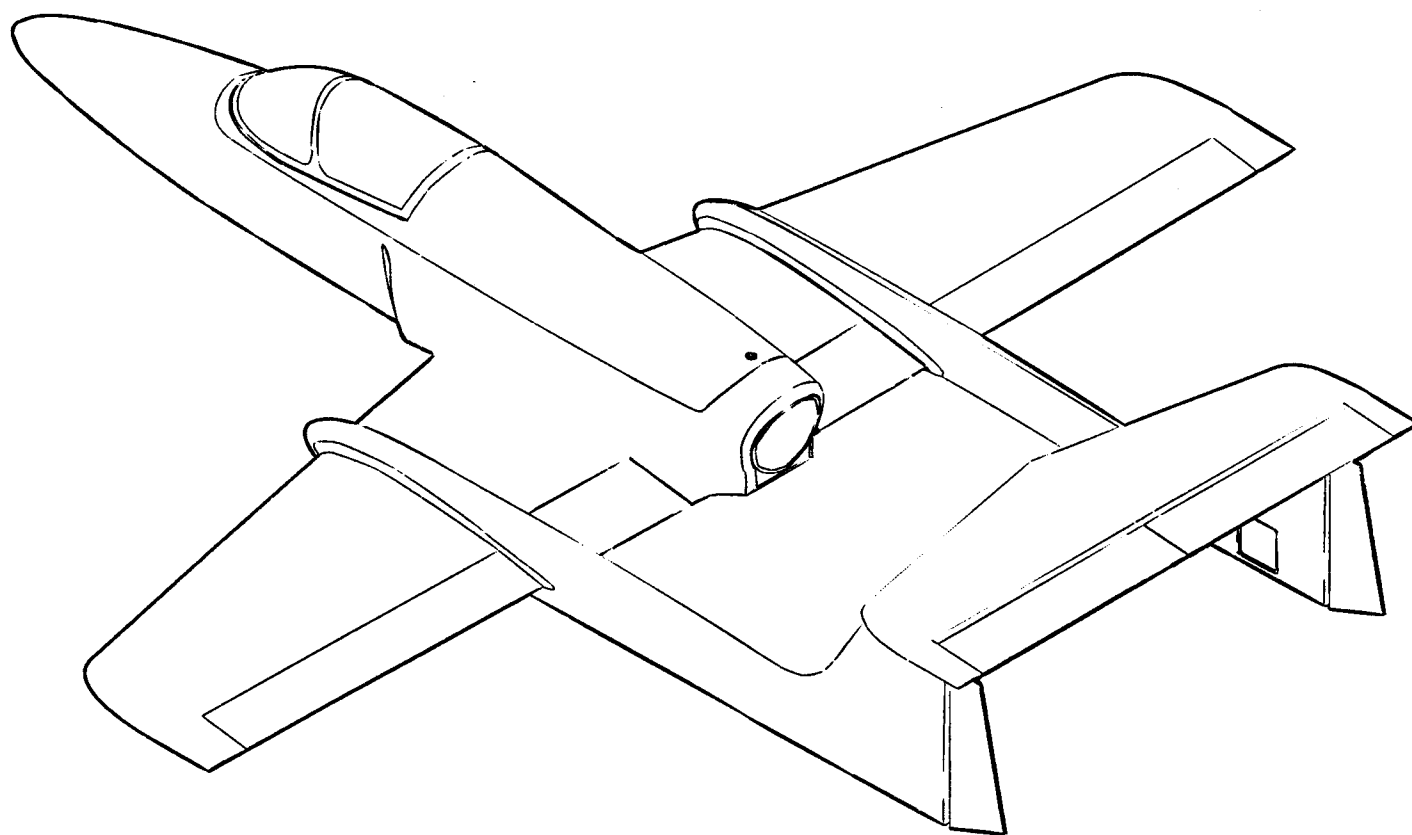

## **Specifications**

Span..... 82.5"

Length..... 80"

Weight 20 lbs.(9 Kilos.)

Radio required 5 to 9 Channels.

Servos 9 to 11.

Designer Alan Cardash

Boomerang Jets Ltd

Website [www .boomerangjets.com](http://www.boomerangjets.com)

## **Safety Precautions**

THE ELAN TURBINE MODEL IS DESIGNED FOR EXPERIENCED MODELLERS. THIS MODEL IS NOT RECOMMENDED FOR BEGINNERS. TURBINE MODELS ARE FOR ADVANCED FLYERS AND SHOULD NOT BE ATTEMPTED BY THOSE WITH INSUFFICIENT BUILDING & FLYING EXPERIENCE. THIS INSTRUCTION MANUAL IS FOR GUIDANCE ONLY. IF YOU ARE UNSURE OF ANY MODEL BUILDING TECHNIQUES, SEEK HELP FROM AN EXPERIENCED MODELLER OR CONTACT BOOMERANG JETS LTD. FOR ASSISTANCE. JET MODELS ARE DANGEROUS IF CONSTRUCTION IS CARELESSLY OR INCORRECTLY CARRIED OUT. AS THE BUILDING AND FLYING OF THIS KIT IS OUT OF OUR CONTROL AFTER POINT OF SALE, NO LIABILITY IS ACCEPTED BY BOOMERANG JETS LTD OR BOOMERANG JETS USA LIC. FOR ANY ACCIDENT OR LOSS, HOWEVER CAUSED. PURCHASE OF THIS KIT IMPLIES ACCEPTANCE OF THESE CONDITIONS BY THE PURCHASER. TO DECLINE THESE TERMS, RETURN UNUSED KIT TO YOUR SUPPLIER FOR A FULL REFUND.

## Note the Symbols used throughout these instructions.

 Assemble left and right sides the same way.

 Not supplied

 Drill holes to the specified diameter (here: 2mm. shown).

 Cut off shaded portion.

 Apply epoxy glue.

 Pay close attention here!

 Ensure smooth non-binding movement while assembling.

 Apply instant glue (CA glue, super glue).

 Do not overlook this symbol!

## 1 Wings

 Assemble left and right sides the same way.

### NOTES ON HORN POSITIONS

Mount the horns so the clevis holes are some 5mm behind the hinge line on ailerons to give differential, & on the hinge line for rudders & elevators. Flap horns are mounted with the clevis holes rearward to maximise the flap travel.

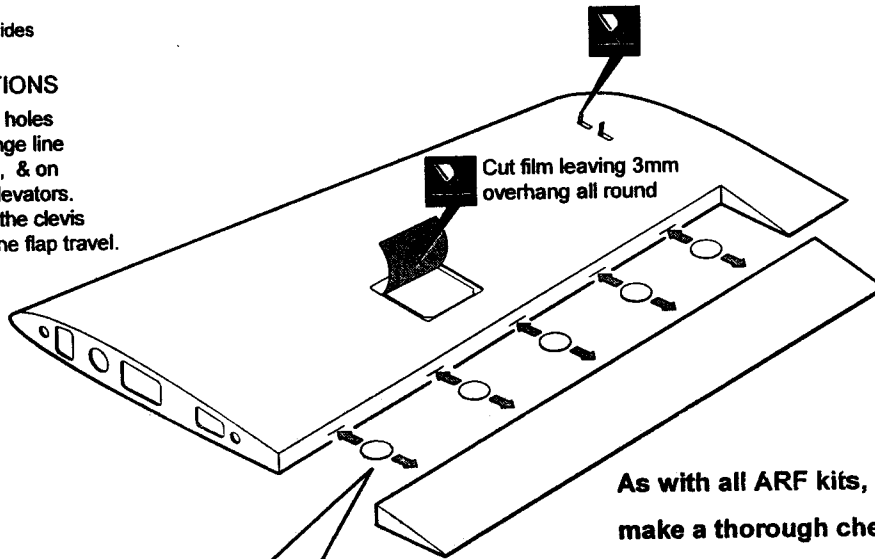

 Be sure to glue securely. This is Vital for safe flying!

Cut film leaving 3mm overhang all round

As with all ARF kits, it is essential to make a thorough check of all glue joints and add epoxy or CA glue if required. Also, pass a hot iron over all the Profilm covering edges, especially leading edges of the covering to ensure adhesion, and then seal these with a clear dope or clear coat using a very small brush.

 Be sure to apply instant type CA glue to both sides of each hinges. (low viscosity type)

## 2 Servo Mounts

 Assemble left and right sides the same way.

Main Wing Installation ..... 2  
 Flap Servo Installation ..... 2  
 Elevator Servo installation ..... 2  
 Rudder installation ..... 2

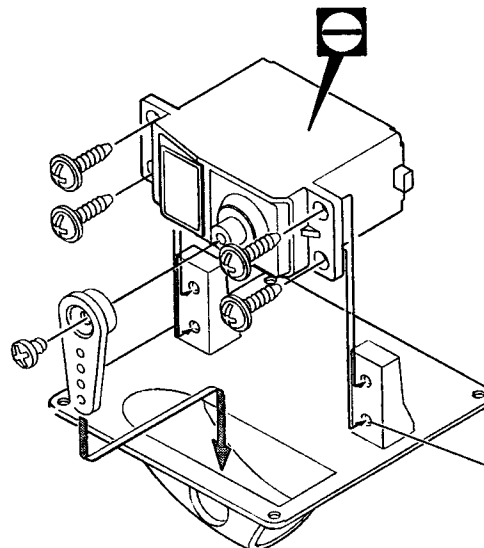

 Position of holes may need adjustment depending on servo brand used

### 3 Servo Mounts

Roughen gluing areas on tip skid, then fix using epoxy glue.

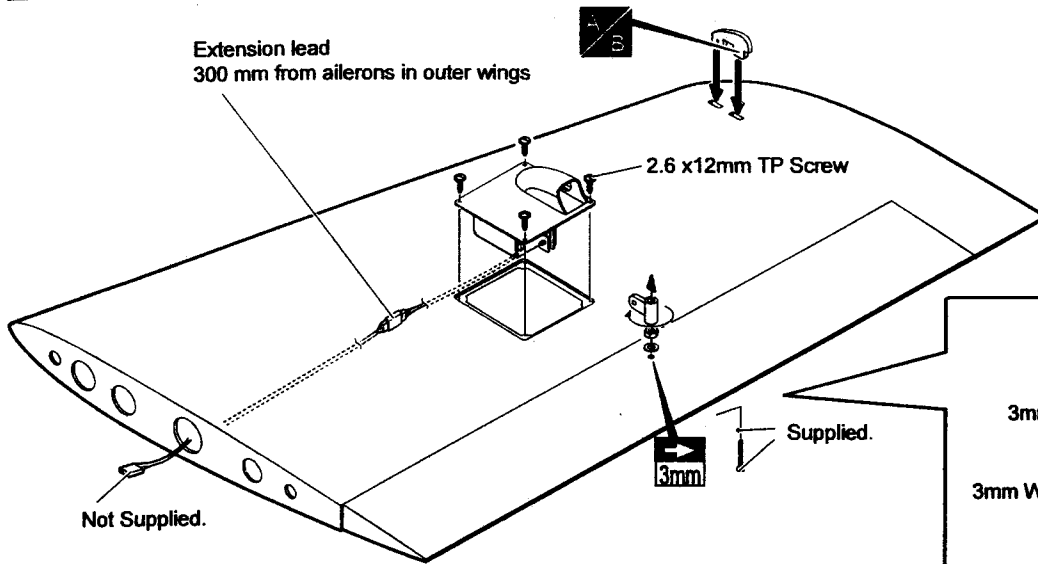

Apply thin cyano top and bottom and immediately tighten the 3mm. nut to prevent the 3mm. bolt rotating.

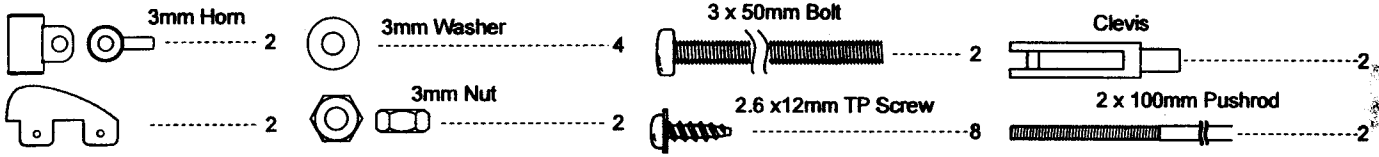
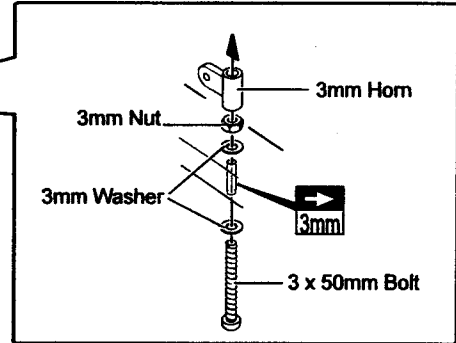

### 4 Pushrods

To Make the Pushrods to the length required;-

- (1) Make a 90 degree bend in the wire at the length required to meet the output hole in the servo arm with the servo centred.
- (2) Now make a second bend off at 90 degrees to the first one, left or right, in the wire at approx. 3mm away from the first bend.
- (3) Straighten the wire by gripping each side of the "Z" bend with pliers and slowly turning until the ends are in line. Now cut off the excess wire. The output hole in the servo arm may have to be drilled out to accommodate the "Z" bend wire passing through it. Adjustment of the pushrod length is carried out by adjusting the clevis along the threaded part of the pushrod.

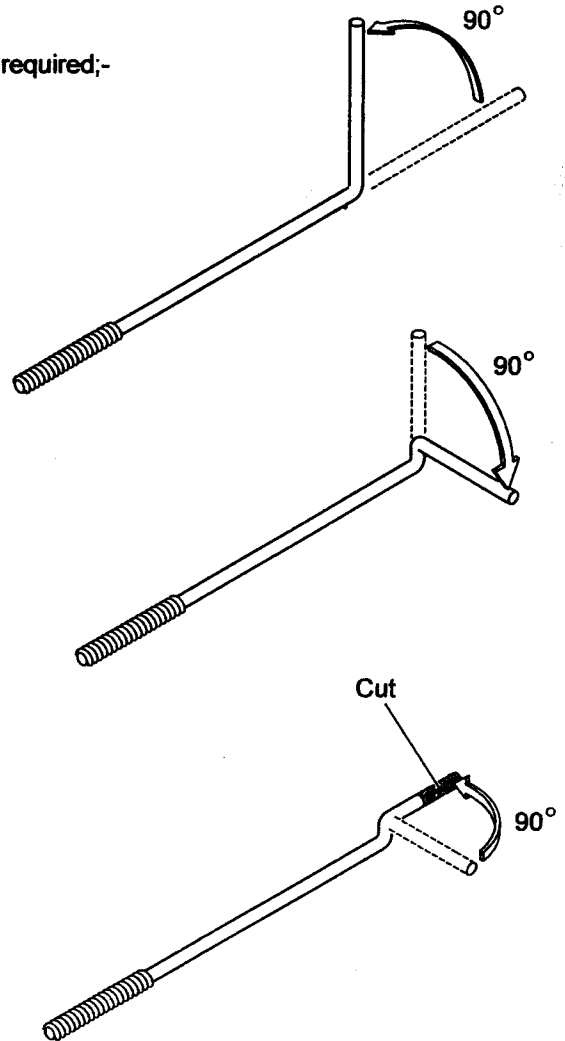

An extra pushrod is supplied to allow for possible error.

## 5 Aileron Servo installation

**L**  
**R** Assemble left and right sides the same way.

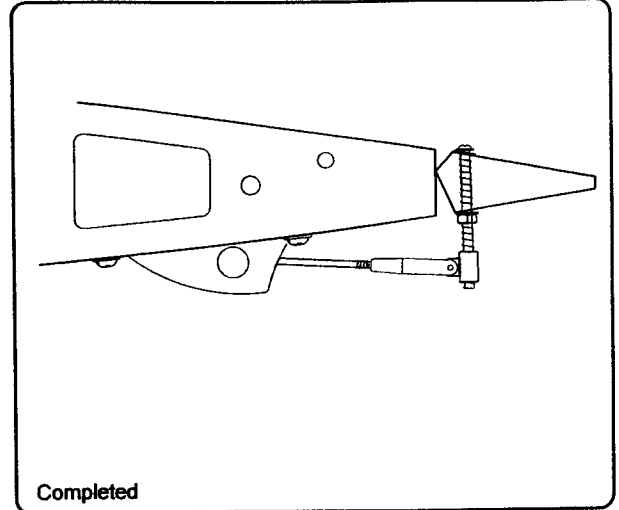
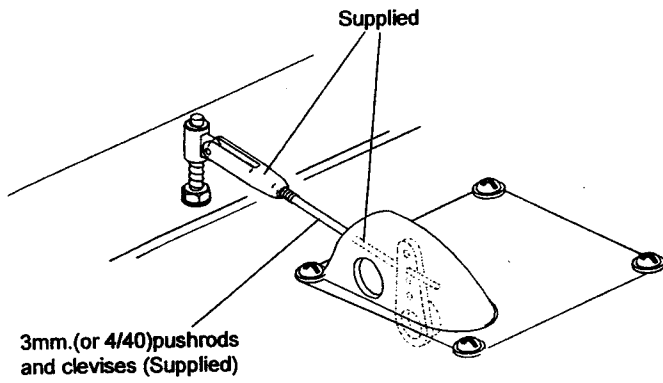

## 6 Flap

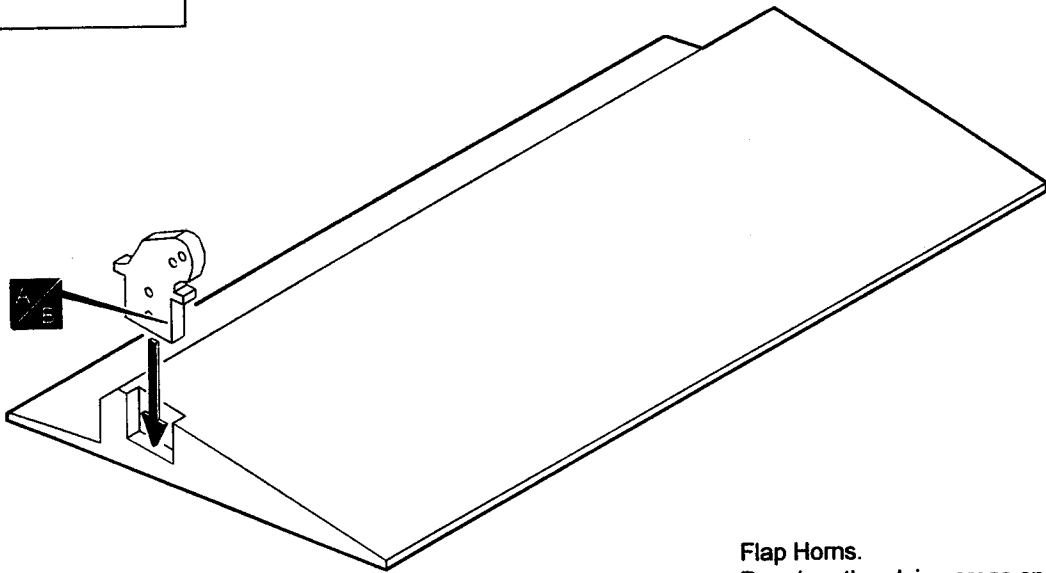

**Flap Horns.**  
Roughen the gluing areas on the flap horns and on the flap itself. Before gluing with epoxy, drill small pilot holes in the flap, then glue and insert pins or small screws (not supplied) to hold the horn and ensure a strong joint.

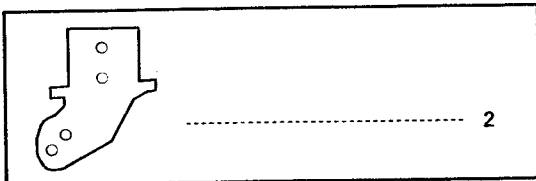

**L**  
**R** Assemble left and right sides the same way.

**Warning!** Be sure to glue securely. This is Vital for safe flying!

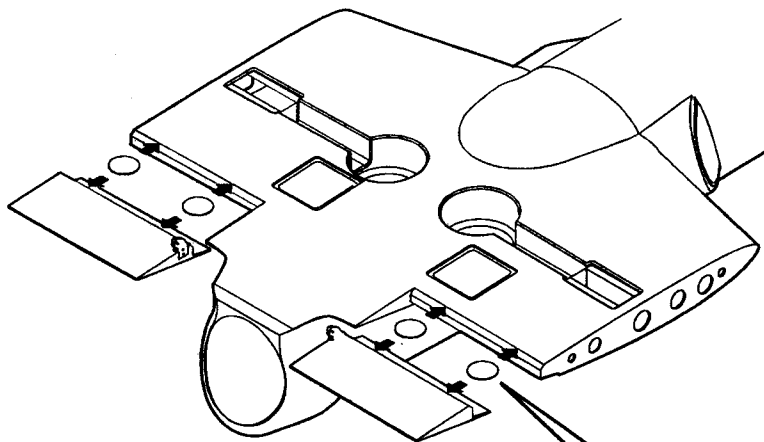

**7** Flap Control

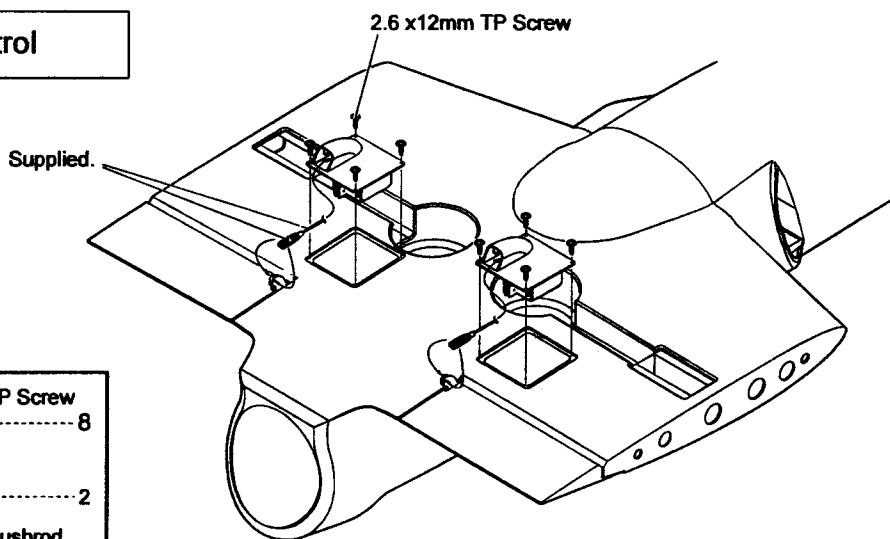

 Be sure to apply instant type CA glue to both sides of each hinges. (low viscosity type)

**8** Flap Control

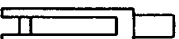

-  2.6 x 12mm TP Screw ..... 8
-  Clevis ..... 2
-  2 x 200mm Pushrod ..... 2

**9** Main Retracts

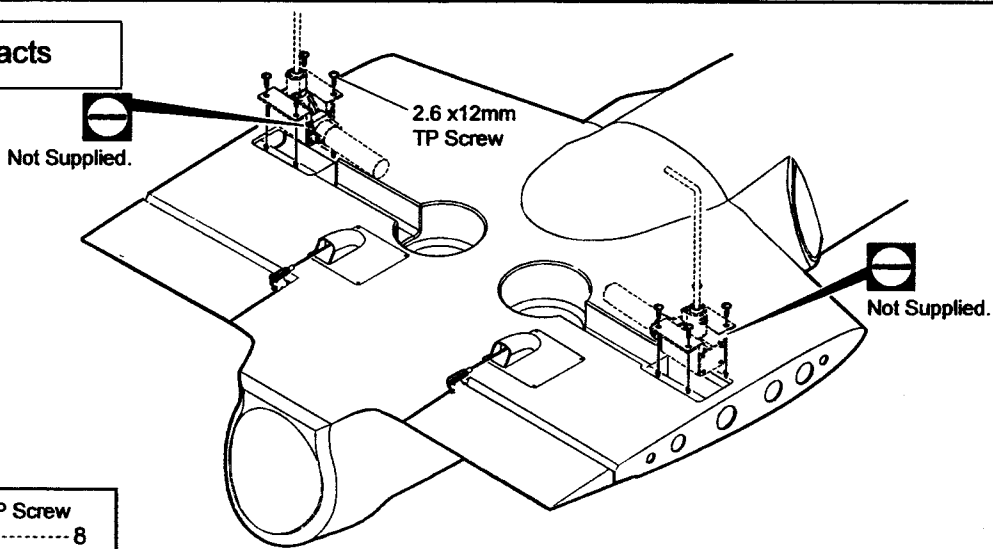

-  2.6 x 12mm TP Screw ..... 8

# 10 Mounting Retracts

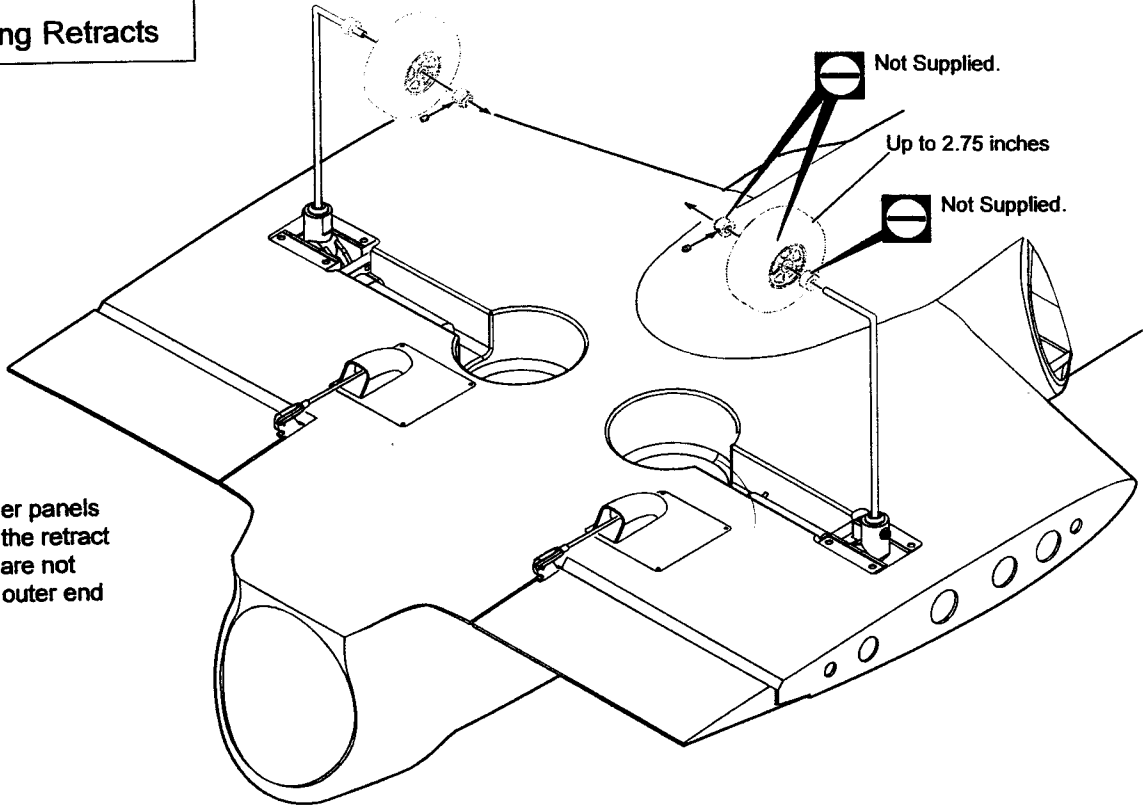

Use plywood filler panels supplied to tidy the retract wells if retracts are not mounted at the outer end of the rails.

# 11 Rudder Servo

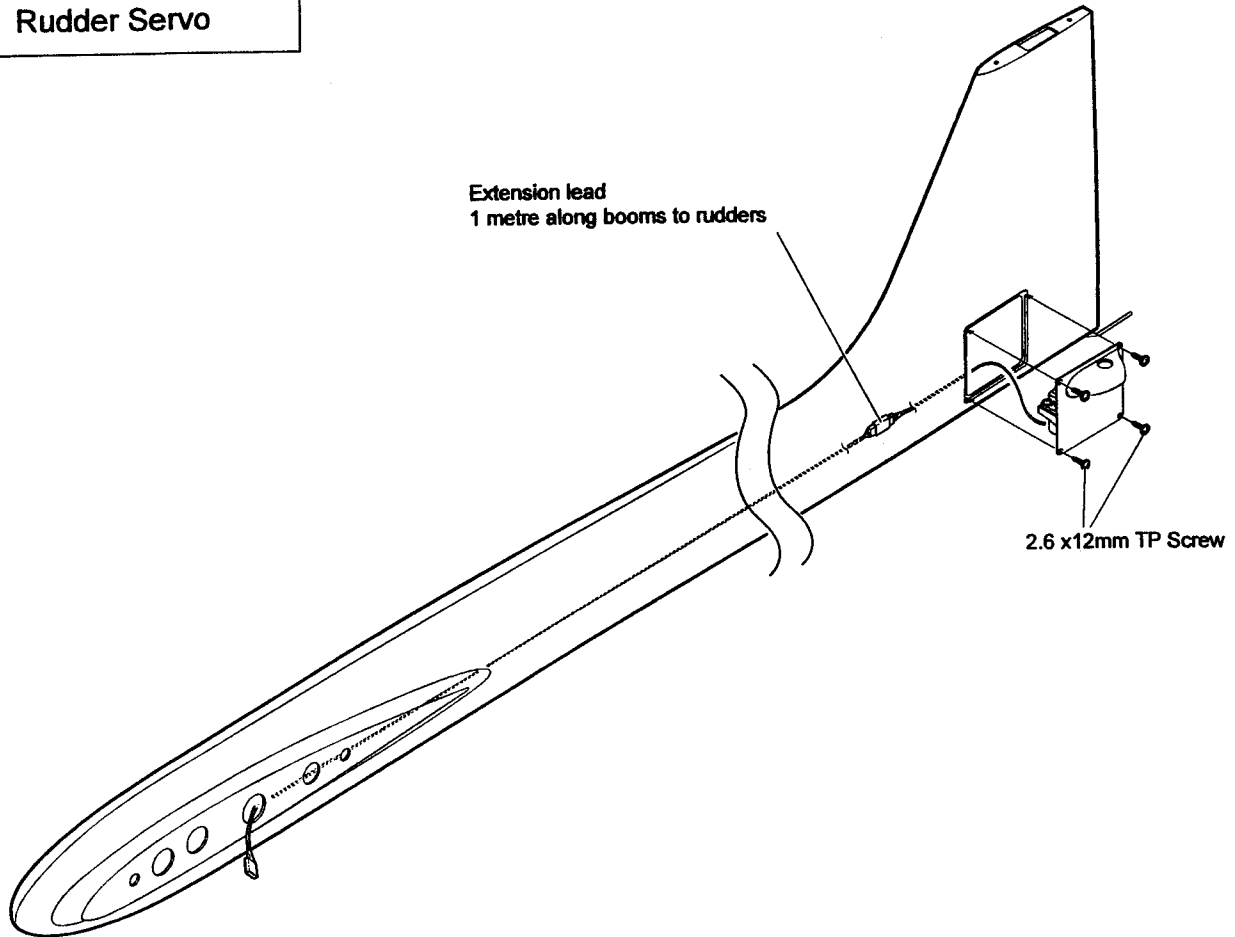

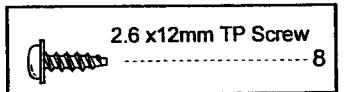

Be sure to glue securely.  
This is Vital for safe flying!



# 12 Rudders

**LR** Assemble left and right sides the same way.

Use thin CA glue both sides of the hinges

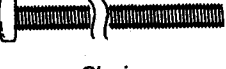
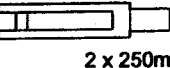
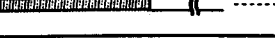
-  3mm Horn ..... 2
-  3mm Washer ..... 4
-  3mm Nut ..... 2
-  3 x 50mm Bolt ..... 2
-  Clevis ..... 2
-  2 x 250mm Pushrod ..... 2

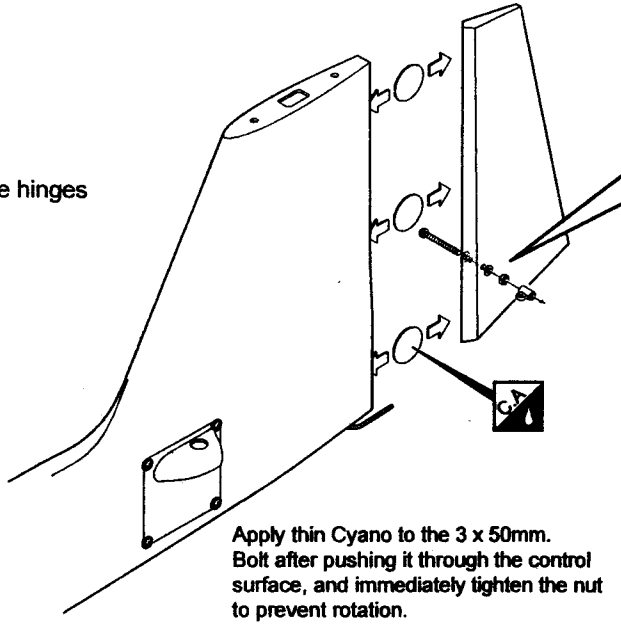

Apply thin Cyano to the 3 x 50mm. Bolt after pushing it through the control surface, and immediately tighten the nut to prevent rotation.

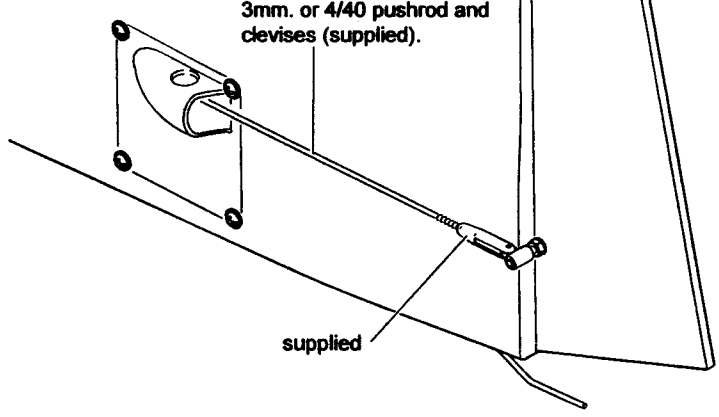
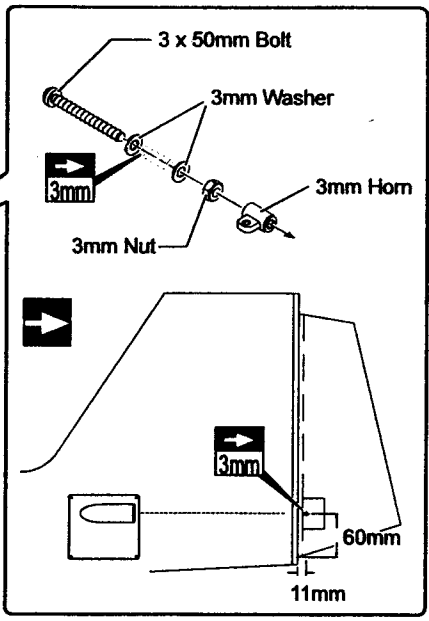

3mm. or 4/40 pushrod and clevises (supplied).

supplied

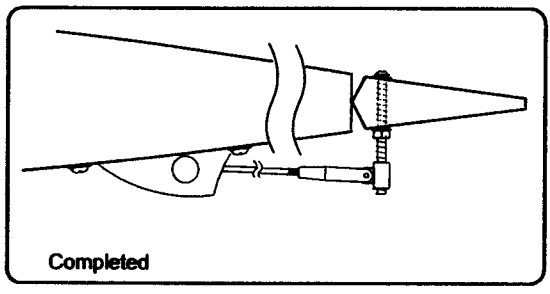

Completed

# 13 Tailplane/Stab

Lightly iron covering through a cloth with warm iron before cutting away covering film, (leaving 3 mm. overhang all round the servo mounts as per the wings).

Cut away covering film.

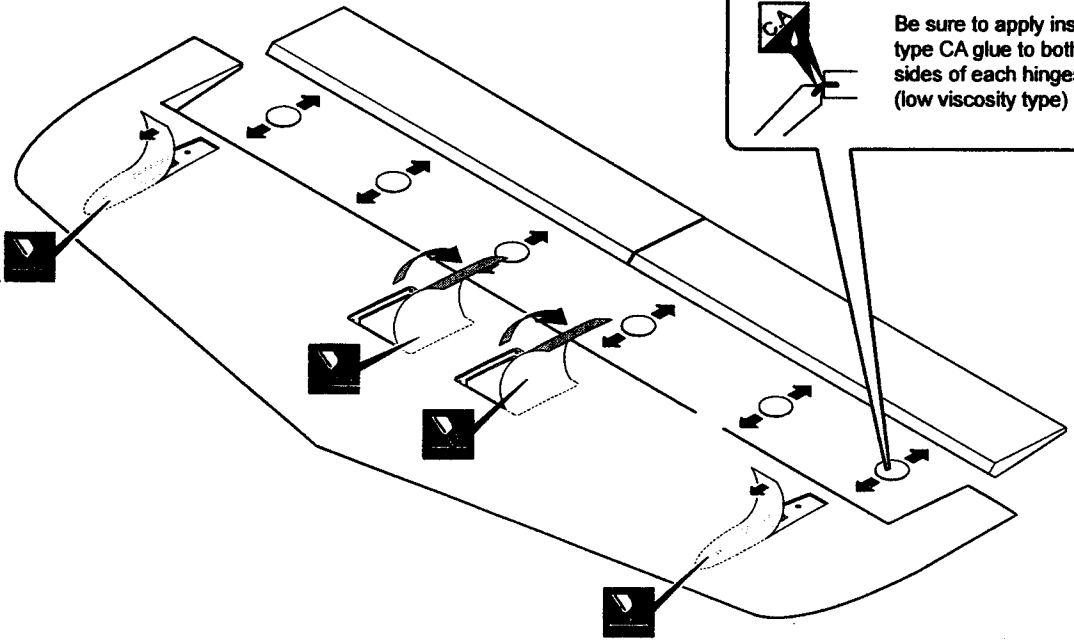





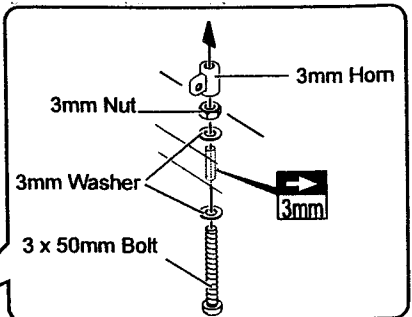
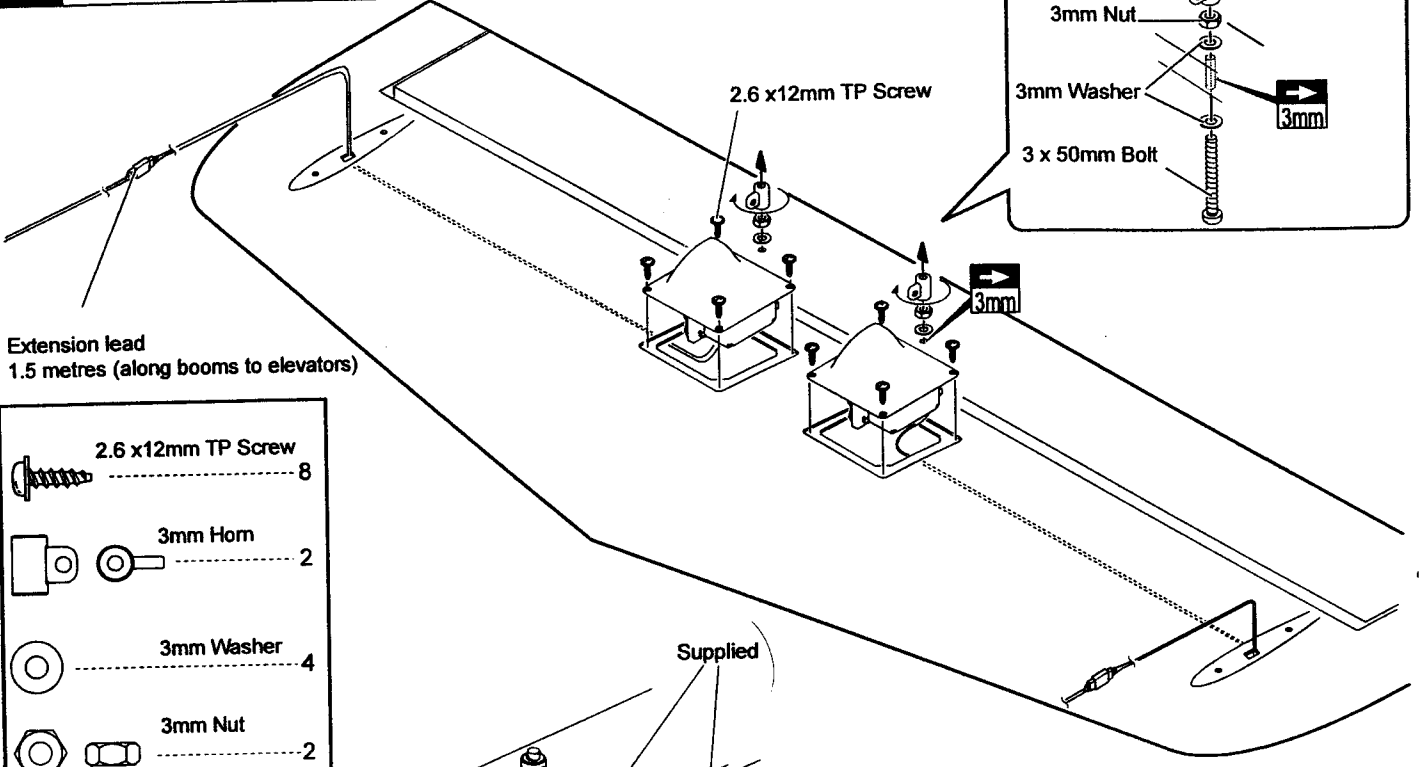

Be sure to apply instant type CA glue to both sides of each hinges. (low viscosity type)

# 14 Tailplane/Stab



Extension lead  
1.5 metres (along booms to elevators)

-  2.6 x 12mm TP Screw ..... 8
-  3mm Horn ..... 2
-  3mm Washer ..... 4
-  3mm Nut ..... 2
-  3 x 50mm Bolt ..... 2
-  Clevis ..... 2
-  2 x 200mm Pushrod ..... 2

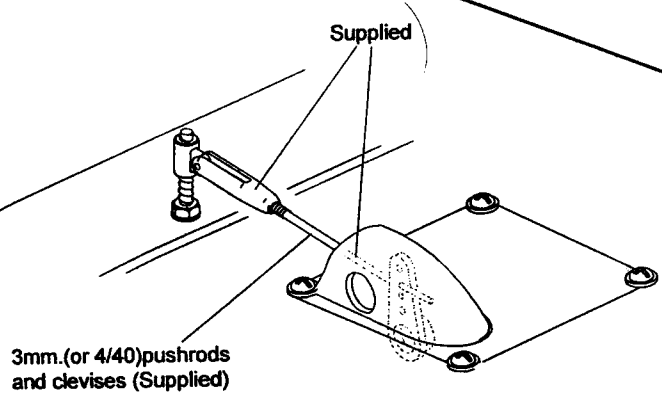

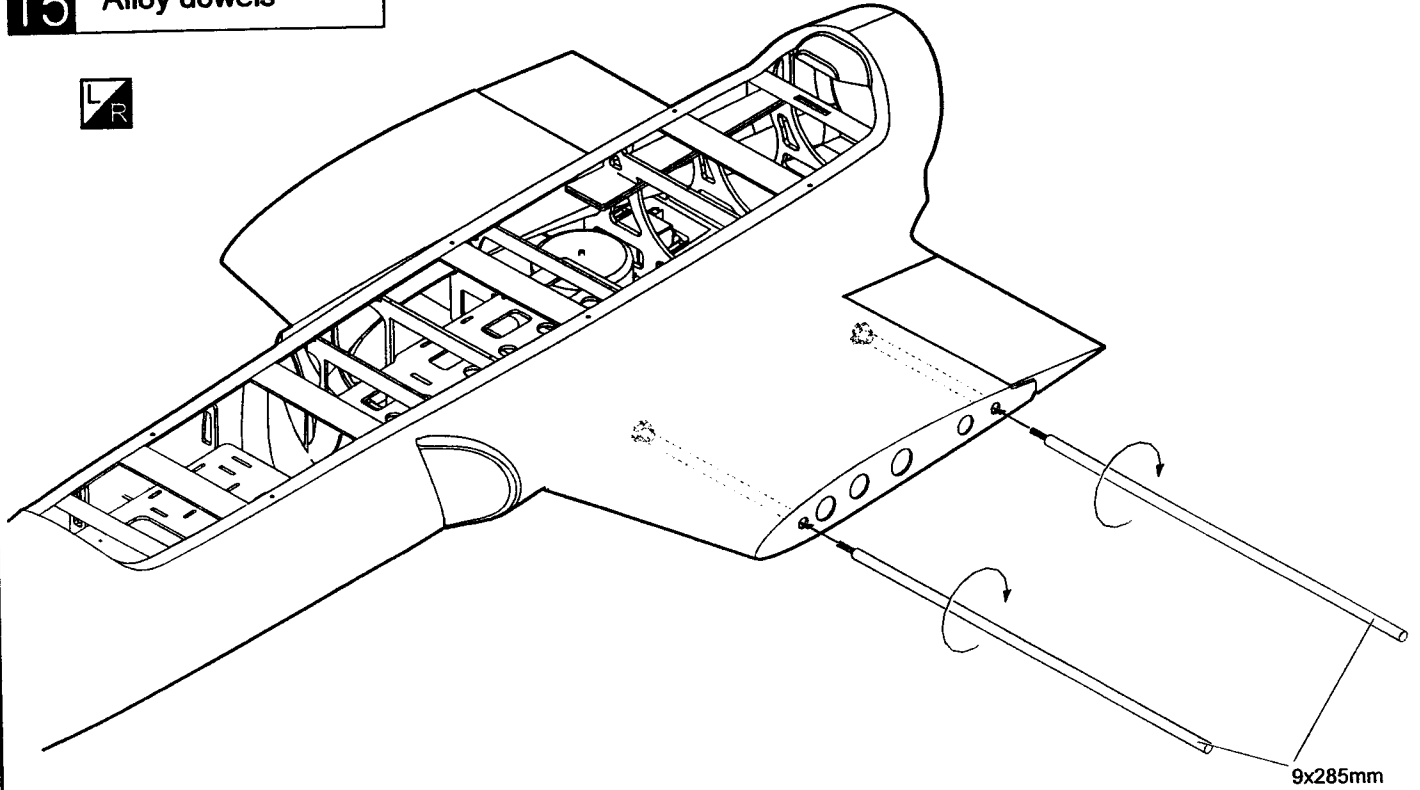

# 15 Alloy dowels



9x285mm

# 16 Assembly

 Assemble left and right sides the same way.

 **Adjusting the Carbon Fibre Spars.**  
If it is necessary to adjust the fit of the C/F spars within the wings, apply the Heatshrink supplied to the spars as shown. The spars should be "snug", but not tight.

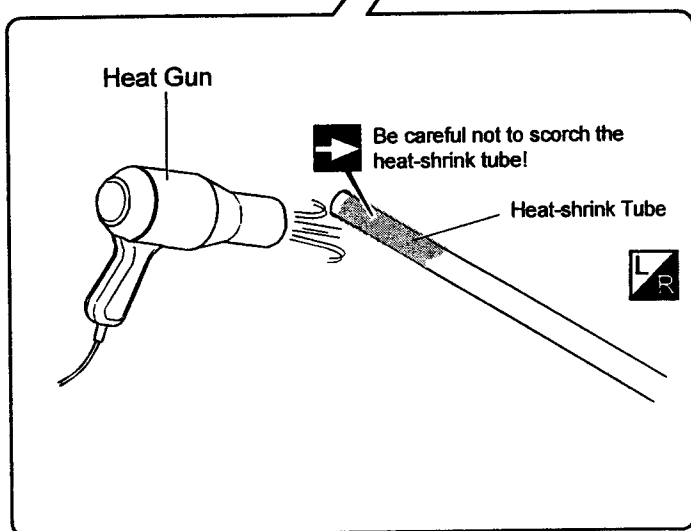
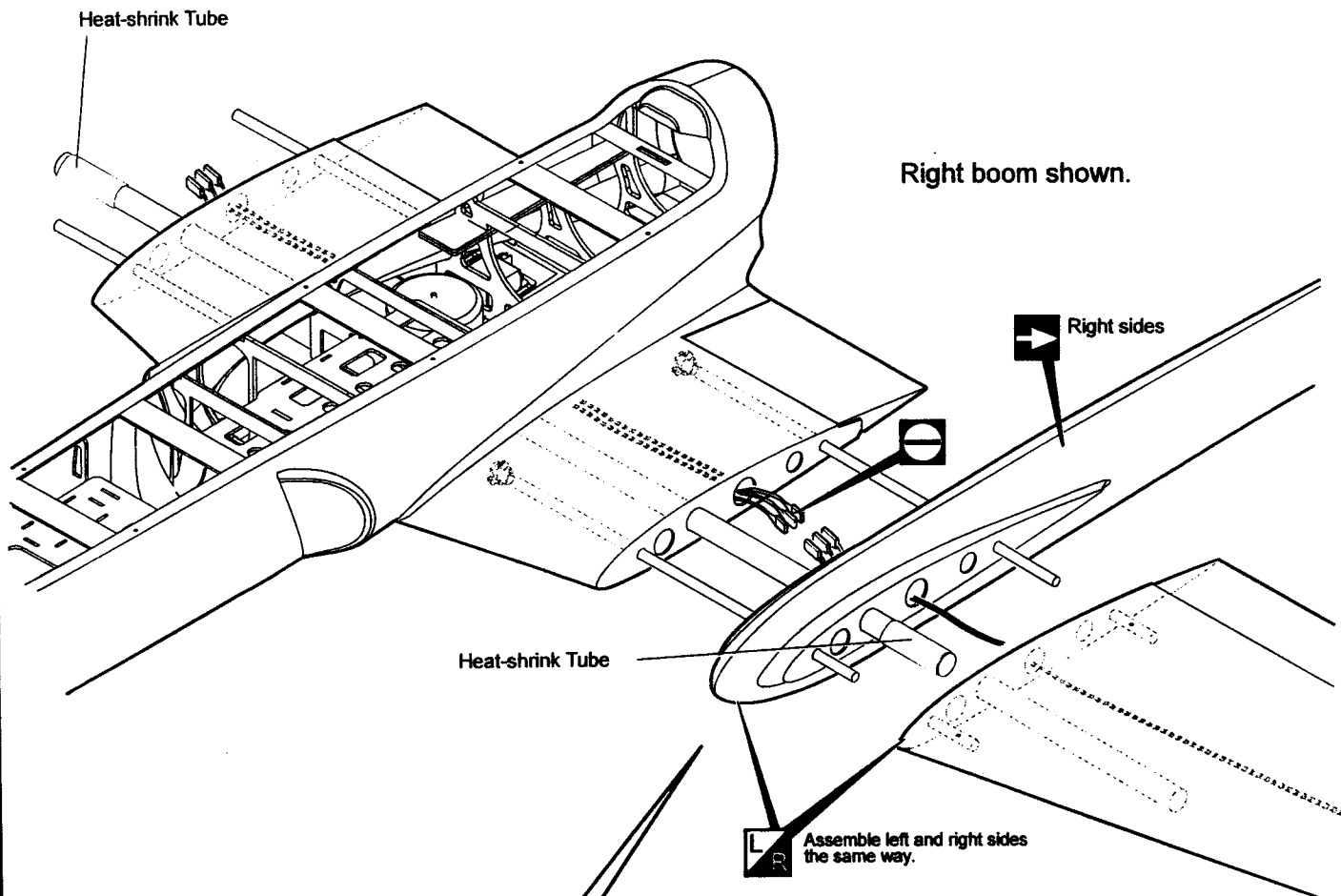

Cut away the plywood stays across the fuselage and the hatch where they are marked. These are for packing only, not structural to the airframe.

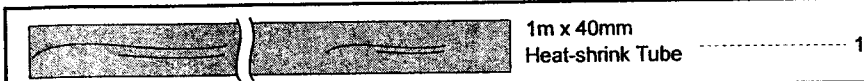

# 17 Wing Locking

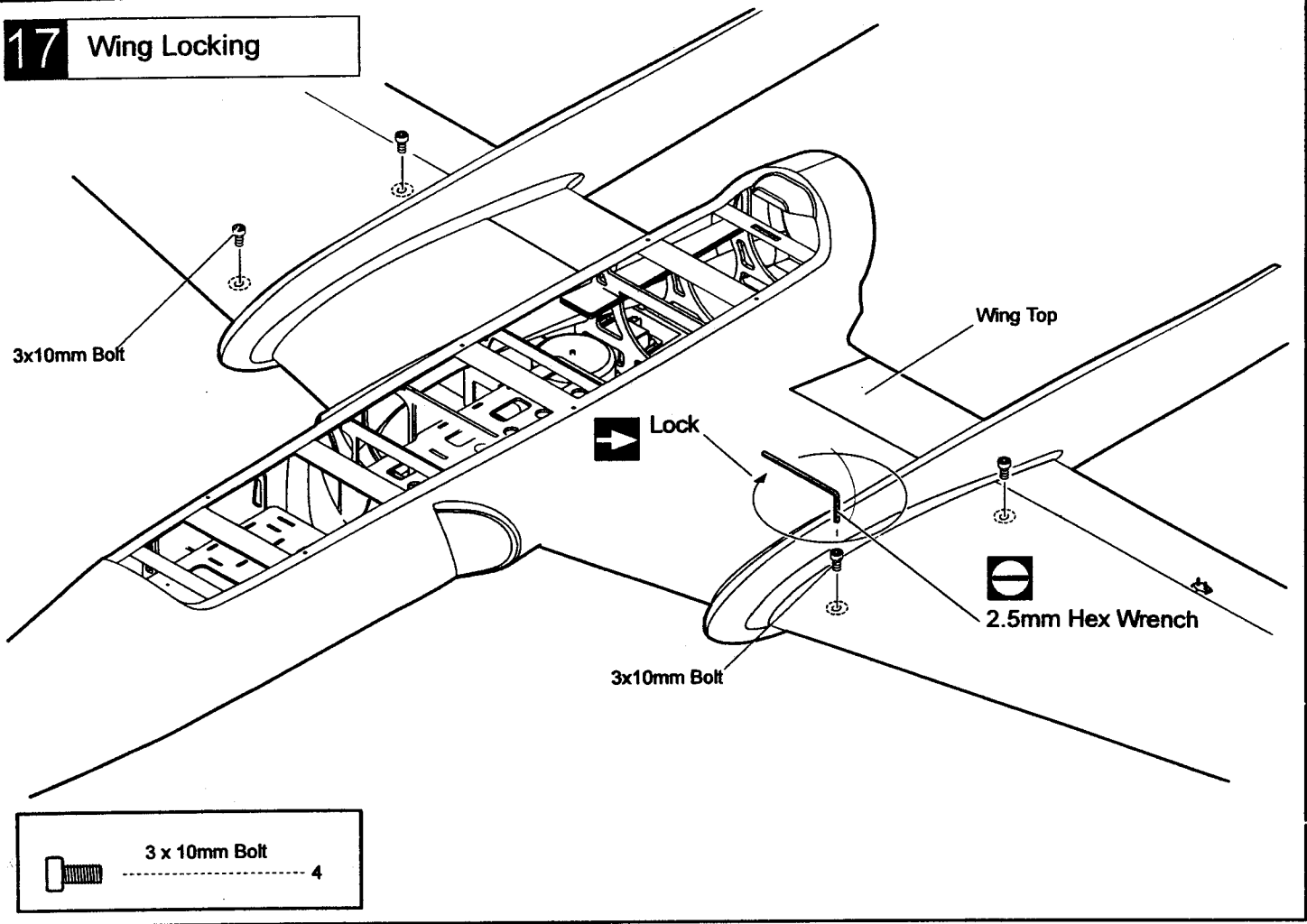

3 x 10mm Bolt 4

# 18 Tail Assembly

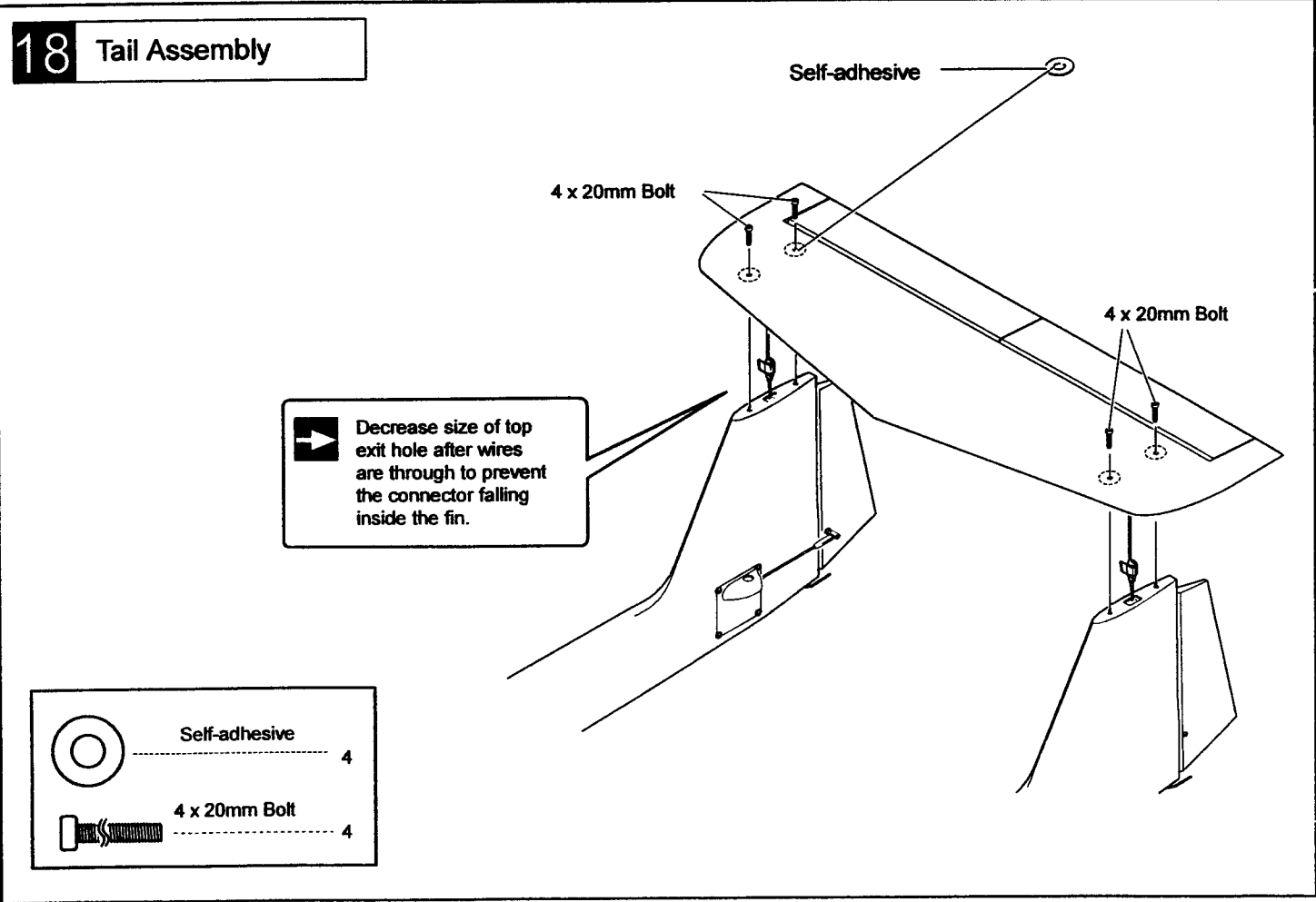

Decrease size of top exit hole after wires are through to prevent the connector falling inside the fin.

Self-adhesive 4

4 x 20mm Bolt 4



## 21 Noseleg Bay Cover

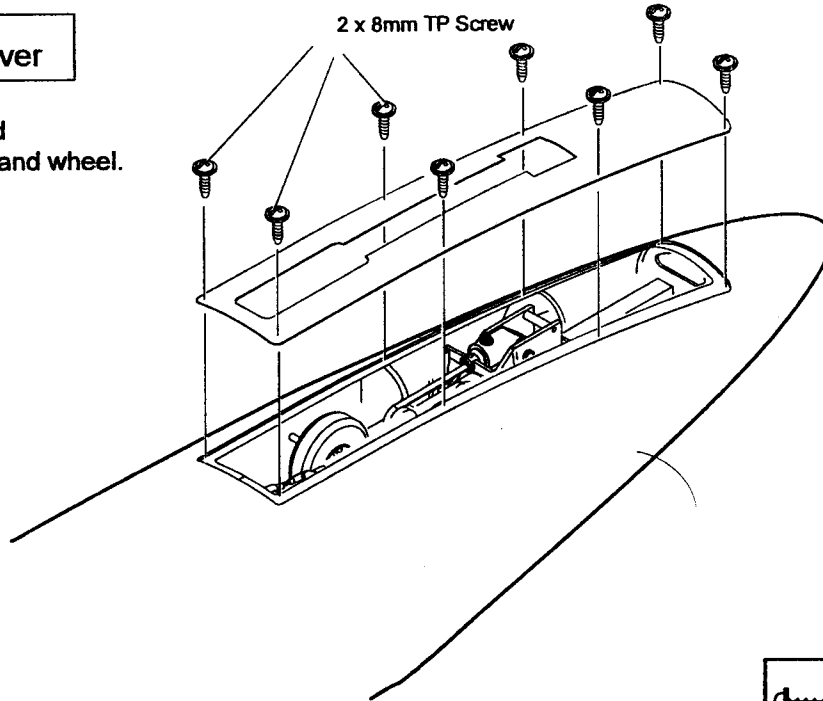

Trim the cover as required to clear the retracting leg and wheel.

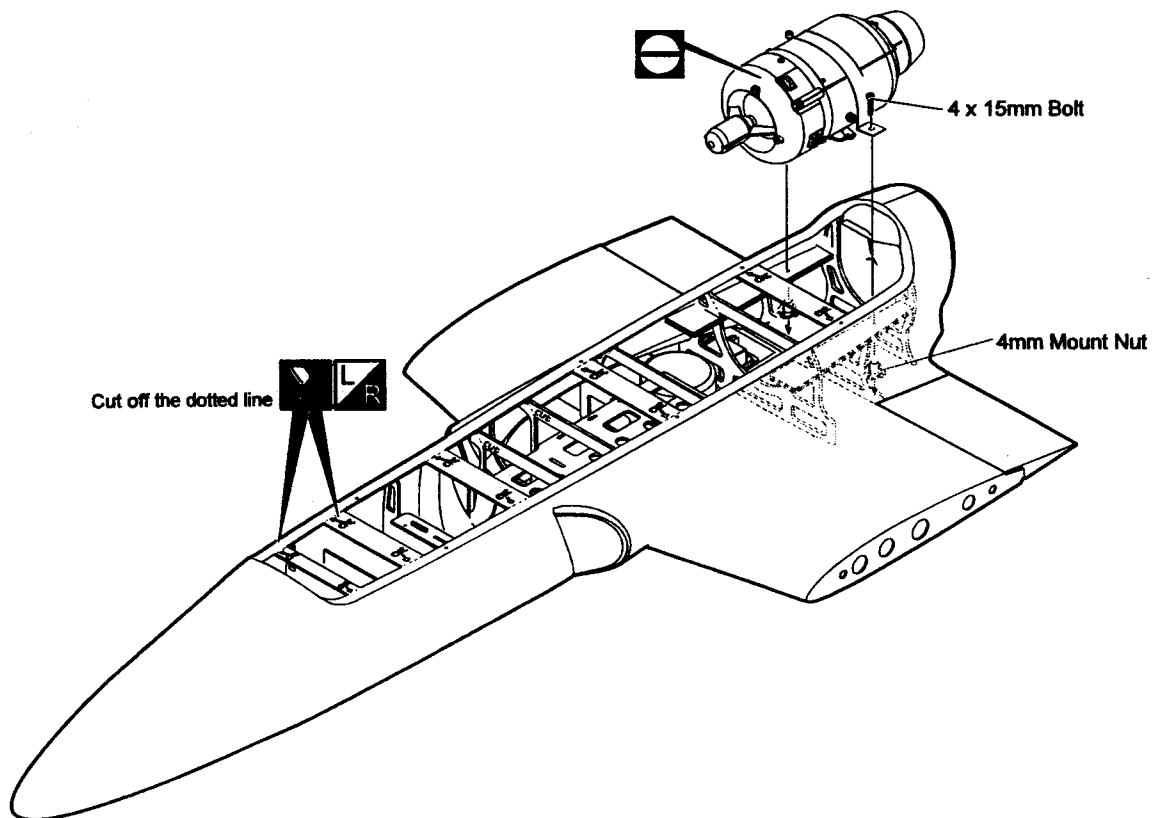

	2 x 8mm TP Screw	8
---	------------------	---

## 22 Fuel Tank etc



	4 x 15mm Bolt	2
	4mm Mount Nut	2

**23** Fuel Tank etc

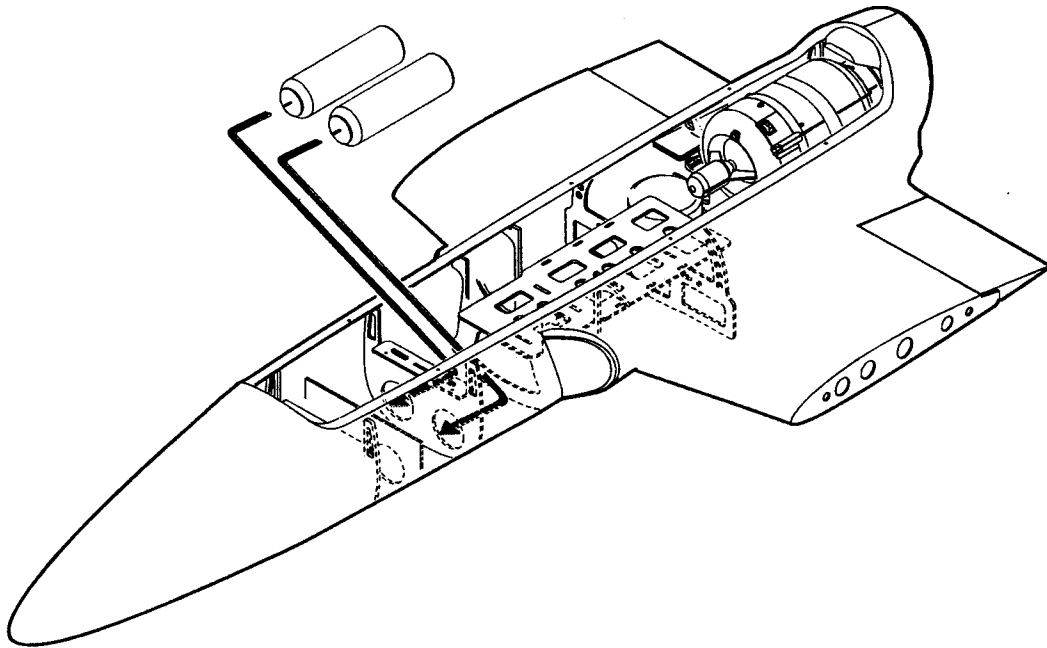

**24** Fuel Tank etc

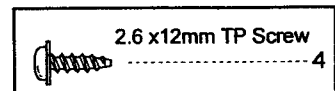
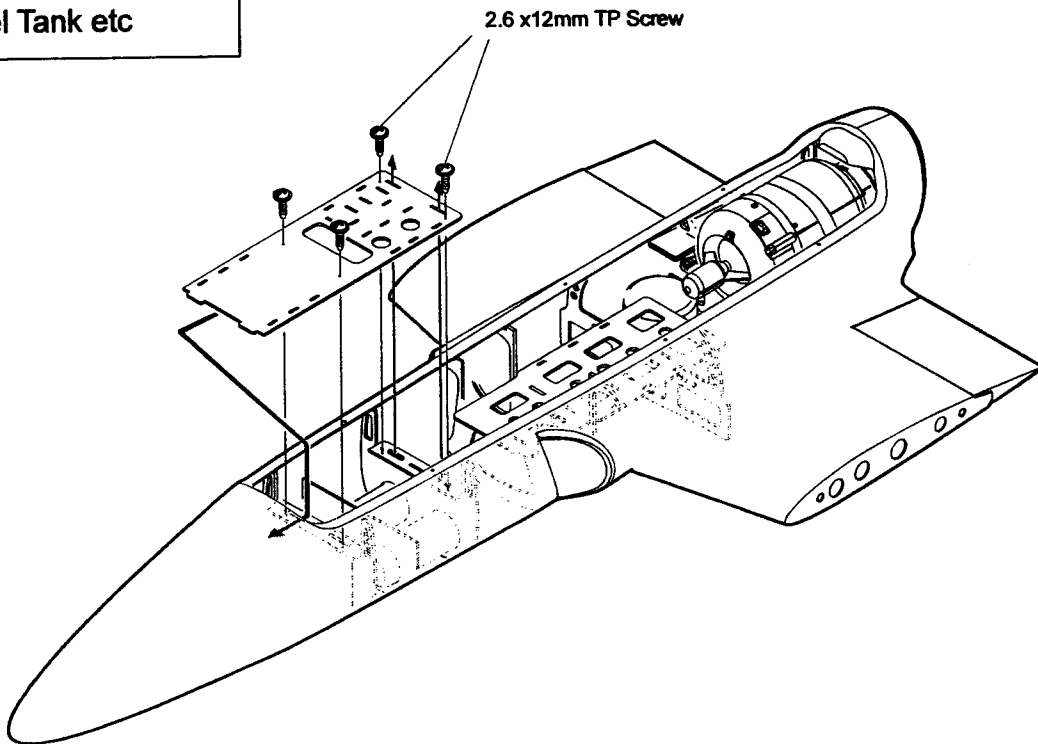

## 25 Fuel Tank

A moulded fuel tank will shortly be available to fit the Elan. Please contact your kit supplier regarding availability. Otherwise it is possible to fit any container from 2 litres up by modifying the fuselage formers as required.

Fix with silicon sealant.

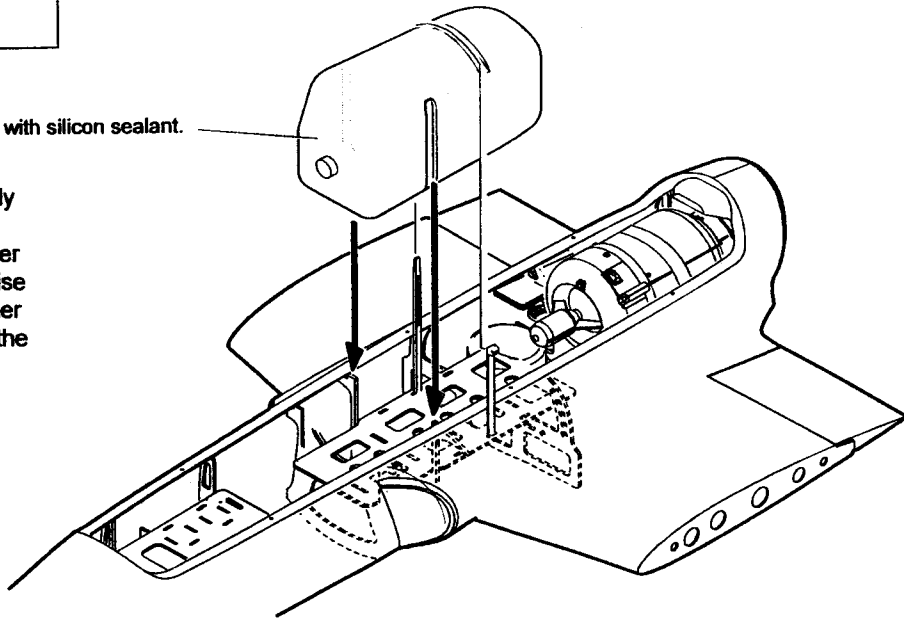

## 26 Cockpit/Canopy

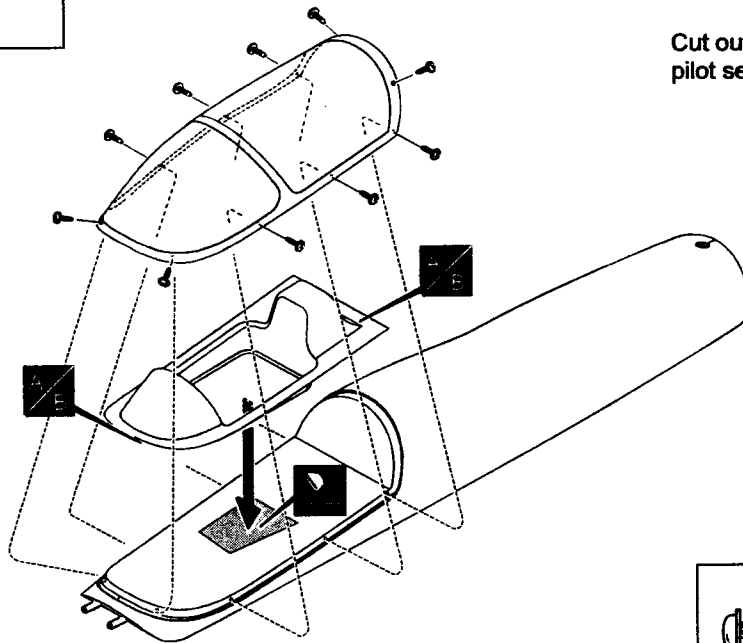

Cut out the cockpit floor to take the pilot seat and glue it in place.



2.6 x12mm TP Screw 10

## 27 Top Hatch

Trim or adjust the dowels if necessary to ensure a good hatch fit. With hatch in place, drill through at rear of hatch and F/G fuselage tab to position the blind nut. Check the fit of 4mm. bolt/hatch, glue blind nut in place.

	4mm Blind Nut	1
	4mm Washer	1
	4 x 15mm Bolt	1

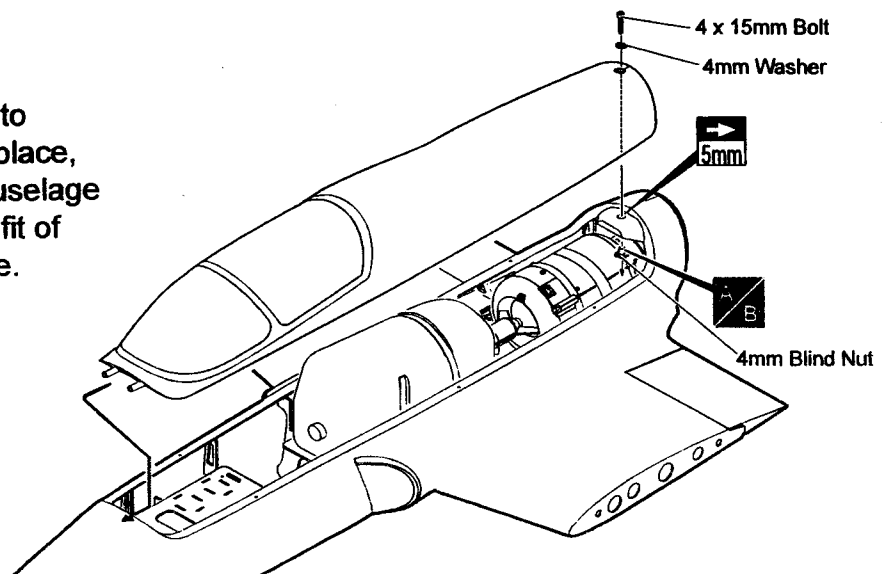

## 28 Setting Up

The CG for the first trimming flights should be as shown. Later you can move the CG back a small amount at a time to increase sensitivity for aerobatics. Set the travel to the values shown below. These can be adjusted later to suit your flying style. Mount the control horns so that the hole for the clevis is at 5 mm. behind the hinge line on the ailerons to provide differential, 10 mm. behind the hinge line for the flaps to maximise movement, and close to the hinge line for the rudders and elevators.



Set the travel to the values show below for the first flights. You can increase these later for aerobatics if desired.



Carefully install the receiver and battery pack to ensure that they will not shift during flight.



Shift the location of the receiver and battery pack as needed to obtain the specified CG.

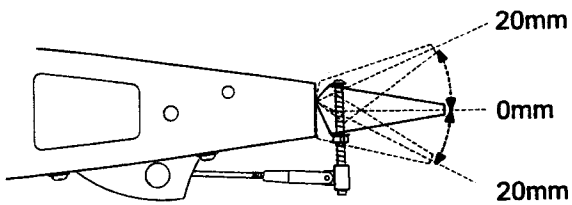

ELEVATOR

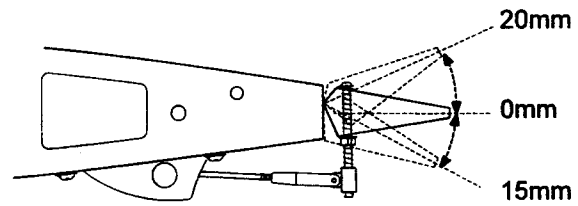

AILERON

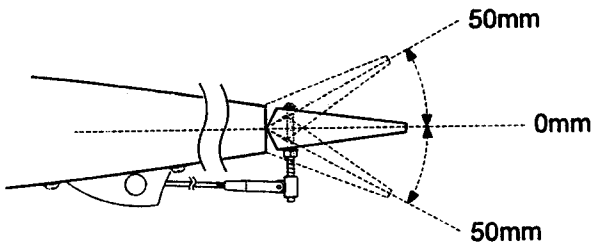

RUDDER

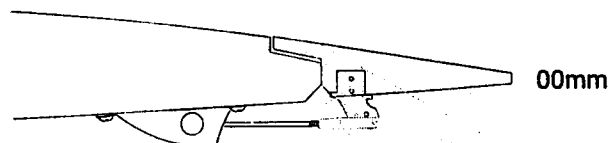

FLAP



For first trimming flights CG should be as shown. Later you can move the CG back a small amount at a time to increase sensitivity for aerobatics.

Flap should drop as near to 90 degrees as possible.

250 mm. from Trailing Edge.  
Dry, with wheels down.



CG

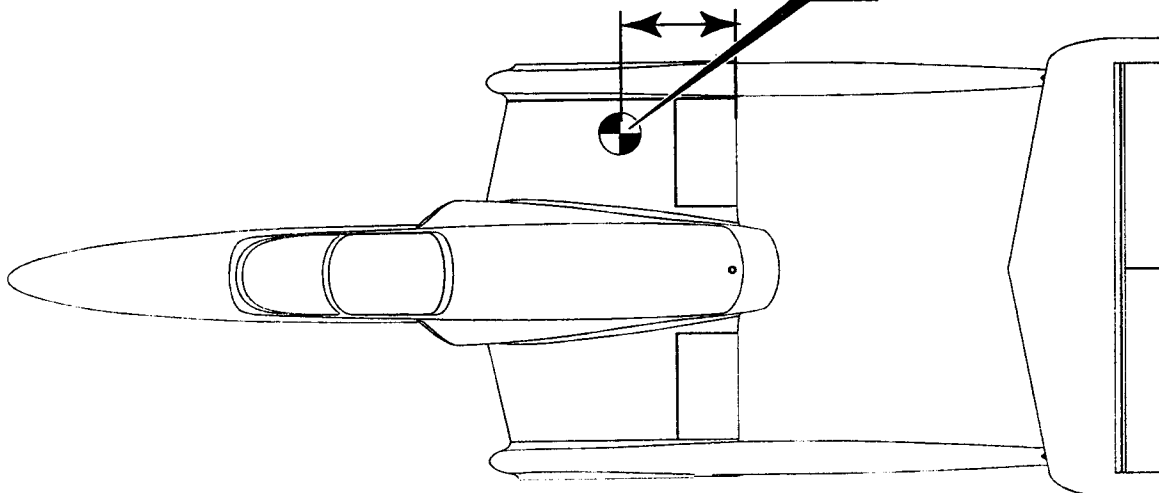

The ELAN is capable of just about any manoeuvre possible with a jet. It lives up to the Boomerang Jets ethos of an easy to build, fly and maintain jet with outstanding flying and aerobatic ability. Take off even on grass is from about 40 feet and landing similarly short in the hands of a competent pilot. Most of the development and testing was done from our 80 yard grass runway ensuring the Elan had to have those characteristics typical of Boomerang models. Steady and solid in slow flight at around 20 mph. it also has exhibited a remarkable top speed over 190 MPH. It has been flown at weights between 18.5 lbs and 23 lbs. with turbines from 14 to the advised maximum 20 lbs thrust. Do not exceed this thrust. For maximum aerobatic performance, keep it light.

The original Elans were flown with the following recommended mixes in the transmitter:

1. Master;- Flap. Mix in 15% down elevator to prevent the nose pitching up.
2. (Only if using two channels for ailerons) Master;- Flap. Mix in UP Ailerons from half down Flap to give both ailerons rising about 3/4" for Crow Braking. This gives amazing slow flight ability without the risk of dropping a wing at high angles of attack using one third to a half throttle.
3. (For easy Knife Edge flight) Master;- Rudder;- Use 8% mix to both Ailerons same control direction as the rudders to lock it in knife-edge without rolling out.